

WE SELL THE
**COMPLETE
PACKAGE**
FOR YOUR SIGN
& STRUCTURAL
ADHESIVE NEEDS

- Abrasives
- Adhesives
- Dispensing Guns
- Sealants

- Silicones
- Tapes
- No-Drill Bonding FastenersTM

Order online at www.chemical-concepts.com or call 1.800.220.1966



Table of Contents

Why Buy?	3
Channel Letter Fabrication	4-5
Lord Signlok or Maxlok™ adhesives.....	4
How to Build Channel Letters.....	5
Lord Adhesive Sign Selector Guide	6-7
Structural Adhesives	8-12
Lord Signlok.....	8
Lord Acrylics.....	9
Lord Epoxies and Urethane adhesives.....	10
Lord 400 & 7500 Series adhesive to use with channel lettering.....	11-12
Weld-On/SCIGRIP Acrylic Cements	13-16
Weld-On/SCIGRIP 15, 45, 4, 40.....	15
Weld-On/SCIGRIP 10, 11, 55, 58.....	16
Potting and Encapsulating Applications	17
Electronics.....	17
Flat Panel Display.....	17
LED Video Display.....	17
LED Lighting—A New Way to Produce.....	18
Adhesive Sealants	19
Acetoxycure silicones.....	19
Neutral cure silicones.....	19
Two component styrene free solvent.....	19
Hybrid Sealants.....	20
Epoxies/Acrylics	21
Aerosols and Pressure Sensitive Adhesives	22
Contact Adhesives.....	22
High Bond Tapes	23-24
General Assembly & Masking Tapes	25
Foam Tapes	26
Tape Information	27-29
Panel Letter Mounting.....	27
LED Mounting.....	27
General Assembly.....	28
Masking.....	28
tesa® ACX Plus chart.....	29
Sanders, Abrasives and Pads	30
Hot Melts	31
Dispense Guns and Mixers	32-33
Chem-Set™ KEEP-NUT™	34
Chem-Set™ No Drill Fasteners	35-39
TYPE M1 Male Bolt Studs.....	36
FTYPE F1 Hex Nuts.....	37
TYPE F2 Female Collars.....	38
Specialty Items.....	39

Why Buy?



Buy from the Adhesive Innovators not the Imitators!

**Rely on the Adhesive Experts...
with answers to your questions based
on over 30 years of experience of
selling to the sign market.**



MEMBERS OF INTERNATIONAL SIGN ASSOCIATION

WHY BUY YOUR ADHESIVES AND SUPPLIES FROM CHEMICAL CONCEPTS?

Our experience is unlike any other general distributor. We focus on adhesives, adhesive systems, and adhesive applications. Using adhesives successfully requires more than just buying the right tube of glue. Proper surface preparation, application methods, fixturing, etc, will determine the difference between 100% success or application failure. We deliver everything you need to get the job done right, including free consultation on special applications.

The track record of Chemical Concepts results from over 50 years of servicing industry markets. Not only do we know adhesives, we know your requirements.

Our stock is fresh. We order more adhesives in one month than a general distributor orders in a year. Plus we have industrial refrigeration in our warehouse to ensure peak product freshness. Our products will never be out of date or improperly stored.

Rely on the Adhesive Experts—with answers to your questions based on our 40+ years of experience servicing fabrication markets.

Top Represented Manufacturers. Learn why our customers continue to stick with us!





Channel Letter Fabrication

Chem-Set™ CHANNEL LETTERING STARTER KIT

Lets Get Started. What You Will Need.

Signlok or Maxlok™ Series

LORD

Structural Adhesives

Two Part Acrylic Adhesive

Metal Bonding Adhesives: Replaces Welding



Fits **Signlok**
Adhesive Series!

520 Dual-Component Gun

- 18:1 Thrust Ratio
- Converts in Just Seconds with Snap In/Snap Out Push Disks
- Patented Cartridge Stabilizing Plate for Extra Support
- Extra Durable, Heat Treated Piston Rod
- Easy Release Star-Burst Reverse Gripping Plate
- Zinc Alloy Handle



GRABS
IN SECONDS
45-60 seconds

FULL CURE
IN 5 MINUTES

CCH220 Hot Melt Gun

- 220 Watts of Power
- For use with 1/2" diameter sticks
- Complete with stand, on/off switch and adjustable thermostat



HM612 Hot Melt Adhesive

- For use with the CCH220 gun
- Bonds to metal
- Holds parts in place as LORD product cures
- Full cure in 5 minutes
- Will not get brittle
- One stick will cover 4 linear feet



Channel Letter Fabrication



HOW TO BUILD CHANNEL LETTERS

The key to a successful channel letter is having the proper tools and using a reliable structural adhesive. We have found the best adhesives for a long lasting bond are **Lord Acrylic Adhesives** used in conjunction with our **HM612 Hot Melt Sticks** and **CCH220 Hot Melt Gun**.



Sheet Metal: Cut and bend sheet metal into the appropriate shape.



Tack: Use the **HM612** Hot Melt Sticks as a clamping or tackdown device while forming the letter. Use the **CCH220 Hot Melt Gun** with glue sticks.



Assemble: Use **Signlok 406** "UL" approved adhesive/sealant around the seams in lieu of welding.

Advantage / Benefits

- **Less skilled labor**
- **Less energy costs**
- **Thinner gauge metal - more choices**
- **NO rust**
- **NO grinding**
- **NO welding**
- **Metal costs savings**

INSTALLING CHANNEL LETTERS

Adhesives can also be used for the installation of channel letters and other types of signs on to a wall. First, surface-mount fasteners are bonded to the backs of the letters or sign. These replace the need for drilling or stud welding. Next, threaded rods of the desired length are attached to the studs. A thread-locking material can be used for additional strength. Holes are drilled into the wall and filled with an epoxy or anchoring adhesive. While 100 percent silicone adhesives have sometimes been recommended for this type of application, it is better to select a true structural adhesive. Finally, the sign is placed on the wall, pushing the threaded rods into the adhesive in the drill holes. The backs of the channel letters can either be installed flush to the wall surface or set out using standoffs for consistent spacing from the wall. It will be necessary to temporarily secure the sign with tape or other means while the adhesive fully cures. For indoor sign installations with lighter loads, double-sided acrylic foam tapes can be used. Installation is easy and the foam tape provides an excellent bond with a clean appearance. It is particularly well-suited for joining dissimilar materials, as the malleable foam allows for differences in thermal expansion in the joint.



LORD[®] Selector Guide

	ALUMINUM/STEEL*	PREFINISHED METAL	POLYCARBONATE*	ACRYLIC*	URETHANE FOAM	PVC FOAM BOARD	CERAMIC/STONE	WOOD
ALUMINUM/STEEL*	Maxlok 4xx/19	Maxlok 4xx/19	+1 877 ASK LORD		7650 7610EZ 7542 7545	Maxlok 4xx/19	320/322†	
PREFINISHED METAL	Maxlok 4xx/19	Maxlok 4xx/19	7542 7545 7610EZ ⁿ	7542 7545 7610EZ ⁿ	7542 7545 7650 7610EZ	Maxlok 4xx/19 7542 7545 7650 7610EZ	320/322†	7542 7545 7650
POLYCARBONATE*	N/A	7542 7545 7610EZ	Maxlok 4xx/19 7542 7545 7610EZ	7542 7545 7610EZ	7542 7545 7650 7610EZ	7542 7545 7650 7610EZ	7610EZ ⁿ	7542 7545 7650 7610EZ
ACRYLIC*	N/A	7542 7545 7610EZ	7542 7545 7610EZ	Maxlok 4xx/19 7542 7545 7610EZ	7550 ⁿ	7542 7545 7650 7610EZ	7610EZ ⁿ	7542 7545 7650 7610EZ
TRIMCAP	Maxlok 4xx/19	7550 ⁿ	7550 ⁿ	7550 ⁿ	7542 7545 7550 ⁿ	7542 7545 7650 7610EZ	N/A	7542 7545 7550 ⁿ
URETHANE FOAM	7660 7610EZ 7542 7545	7542 7545 7650 7610EZ	7542 7545 7650 7610EZ	7542 7545 7650 7610EZ	7542 7545 7550 ⁿ	7542 7545 7650 7610EZ	7610EZ ⁿ	7542 7545 7650 7610EZ
PVC FOAM BOARD	Maxlok 4xx/19	Maxlok 4xx/19 7542 7545 7650 7610EZ	7542 7545 7650 7610EZ	7542 7545 7650 7610EZ	7542 7545 7650 7610EZ	7542 7545 7650 7610EZ	7610EZ ⁿ	7542 7545 7650 7610EZ
CERAMIC/STONE	320/322†	320/322†	7610EZ ⁿ	7610EZ ⁿ	7610EZ ⁿ	7610EZ ⁿ	320/322	7610EZ ⁿ
WOOD	N/A	7542 7545 7650 7610EZ	7542 7545 7650 7610EZ	7542 7545 7650 7610EZ	7542 7545 7550 ⁿ	7542 7545 7650 7610EZ	7610EZ ⁿ	7542 7545 7650 7610EZ
CURED CONCRETE	7610 320/322	320/322 360	7610EZ	7610EZ	N/A	N/A	320/322	7610EZ 320/322
GLASS	Maxlok 4xx/19	Maxlok 4xx/19	N/A	N/A	N/A	N/A	N/A	N/A

xx – Represents numbers for the family of adhesives to be utilized. Contact LORD Customer Support Center.

N – For non-structural bonding (assemblies where adhesive is used for aesthetic attachment in minimum stress areas).

* – Coefficient of thermal expansion is a major consideration when cross-bonding these substrates. Acrylic adhesives should not be used to attach large thermoplastic parts due to the differences in thermal expansion.

† – Prepare metal by scuffing/abrading followed by a solvent wipe.

NOTE: LORD 406/19, 403/19, and 7542 are all UL recognized.



LORD® Selector Guide

SUBSTRATE CLASS	SUBSTRATE TRADENAME**	SUBSTRATE SUPPLIER	SUBSTRATE PREP	LORD ADHESIVE
ACRYLIC SHEET	Acrylite®	Evonik Cyro	Scuff	LORD 7545 or 7542, Maxlok
	Acrysteel® IGP	Aristech Acrylics	Scuff	LORD Maxlok, 4xx/19, 7545 or 7542
	Duraplex®	Plaskolite	Scuff	LORD Maxlok, 4xx/19, 7545 or 7542
	Optix® SG	Plaskolite	Scuff	LORD Maxlok, 4xx/19, 7545 or 7542
	Implex®	Arkema	Scuff	LORD Maxlok, 4xx/19, 7545 or 7542
	Plexiglas® G	Arkema	Scuff	LORD Maxlok, 4xx/19, 7545 or 7542
ALUMINUM	—	—	SW	LORD 4xx/19
PAINTED ALUMINUM	AlumaCorr™	Nudo Products	Scuff	LORD Maxlok, 4xx/19, 7545 or 7542
	NuAlum™	Nudo Products	Scuff	LORD Maxlok, 4xx/19, 7542, 7545 or 7650
	Poly-Metal™	Nudo Products	Scuff	LORD Maxlok, 4xx/19, 7542 or 7545
	Alumalite™	Laminators Inc.	DRW/Scuff	LORD Maxlok, 4xx/19, 7545 or 7542
	DiBond®	3A Composites	DRW	LORD Maxlok, 4xx/19 or 7610EZ
	Econolite™	Laminators Inc.	DRW/Scuff	LORD Maxlok, 4xx/19, 7545 or 7542
	MAXX™	Amerimax Building Products	SW	LORD Maxlok, 4xx/19, 7545 or 7542
	Alucobond®	3A Composites	SW	LORD Maxlok, 4xx/19, 7542, 7545 or 7610EZ
Anodized Alucobond®	3A Composites	SW	LORD Maxlok or 4xx/19	
PAPER/FOAM BOARD	Foam-X® Recovery	3A Composites	DRW	LORD 7545, 7542 or 7650
	Fome-Cor®	3A Composites	DRW	LORD 7545, 7542 or 7650
PETG SHEET	Spectar™ PETG	Eastman Chemical Company	DRW	LORD Maxlok, 4xx/19, 7545 or 7542
POLYCARBONATE SHEET	Lexan®	General Electric	DRW	LORD 7550 (Cosmetic/non-structural)
	Tuffak®	Bayer MaterialScience	DRW	LORD Maxlok, 4xx/19, 7545 or 7542
POLYSTYRENE FOAM BOARD	Gatorfoam®	3A Composites	DRW	LORD 7545, 7542, 7650 or 7610EZ
	Gatorblanks®	3A Composites	DRW	LORD 7545, 7542, 7650 or 7610EZ
	Ultra	United Industries	SW	LORD Maxlok, 4xx/19, 7542, 7545, 7610EZ or 7650
EXPANDED PVC/FOAM BOARD	Komatex®	Kommerling USA, Inc.	Scuff	LORD Maxlok, 4xx/19, 7545 or 7542
	Sintra®	3A Composites	Scuff	LORD Maxlok, 4xx/19, 7545, 7542 or 7610EZ
VINYL LAMINATE	White-Wood®	Nudo Products	DRW/Scuff	LORD 7545, 7542 or 4xx/19
	Maxx-Board™	Amerimax Building Products	SW	LORD Maxlok, 4xx/19, 7542, 7545 or 7650
TRIMCAP	Jewelite®	Wagner Zip-Change, Inc.	SW/Scuff	LORD 7550
	SignATrim™	Transco	SW/Scuff	LORD 7550
HIGH DENSITY URETHANE FOAM	Precision Board	Coastal Enterprises, Inc.	DRW	LORD 7542, 7545, 7610EZ or 7650
	Last-A-Foam®	General Plastics Mfg. Co.	DRW	LORD 7542, 7545, 7610EZ or 7650
	Sign Foam 3®	Sign Arts Products Corp.	DRW	LORD 7542, 7545, 7610EZ or 7650
	Design Board®	Jasper Plastics	DRW	LORD 7542, 7545, 7610EZ or 7650
CERAMIC/STONE	—	—	DRW	LORD 320/322
WOOD	—	—	DRW	LORD 7545, 7542, 7650 or 7610EZ

xx – Represents numbers for the family of adhesives to be utilized. Contact LORD Customer Support Center.

NOTE: "DRW" means dry rag wipe. This preparation process simply cleans dust from a surface. "Scuff" means to use an abrasive pad to lightly rub the surface of the substrate. This roughens the surface slightly, improving adhesion. "SW" means solvent wipe with isopropyl alcohol. Contact a LORD representative for recommendations.

Each substrate and adhesive should be tested for the specific use in which it will be expected to perform. The information reported here is from laboratory studies and is intended only to provide general information regarding the ability of material to be bonded with LORD® Structural Adhesives.

Other substrates or grades of substrates from these and other suppliers may not have been evaluated for adhesion. If you need to bond a substrate that is not on this list, call your substrate supplier or LORD Customer Support Center.

** All substrate tradenames are trademarks or registered trademarks of the substrate supplier.



LORD® Structural Adhesives

LORD Signlok Adhesives

LORD® Signlok 810

Elevate your metal and metal composite designs!

Bond thin gauge metal materials with no bond-line read-through or surface distortion with LORD® Signlok 810 Adhesive.

Design Flexibility with Uncompromised Aesthetics

- Designed for aluminum composite materials and bonds thin-gauge metal-to-metal and metal-to-composites/plastics
- No bond-line read-through or surface distortion
- **Flexible, low exotherm, low shrinkage**
- Glass beads for precise bond-line control
- Non-sagging
- UL Approved
- 180% elongation

Optimize Production & Costs

- 90% full cure within one hour
- Minimal surface preparation required
- New packaging fits most jobs and eliminates waste
- Two mixing tips included with each cartridge to control cost

LORD® Signlok 400 Series

Versatile, Durable and Convenient Solutions

Control costs, reduces waste, enhance productivity and performance with LORD® Signlok 400 Series Adhesives

Features & Benefits

- Durable enough to replace welds, rivets and other mechanical fastening methods
- Available in a range of work times accommodating a variety of process requirements
- Right size packaging fits most jobs and eliminates waste
- **18 MONTH SHELF LIFE**; reduces cost of discarding out-of-date material
- **CONTAINS GLASS BEADS** to enable precision bond-line control and manage waste





LORD® Structural Adhesives

LORD Acrylic Adhesives



LORD Maxlok (MX/T3, MX/T6, MX/T18)*†

LORD 400 Series (403/19, 406/19, 410/19)*†

LORD 200 Series (201/19, 204/19, 206/19)†

- Little to no surface prep • PVC • Bare Metal
- Painted Metal • Fiberglass • Acrylic • Glass
- Standard bearer in metal bonding

For metal and cross bonding.



LORD® 406/19

Two Part Epoxy Adhesive

- Bonds unprepared metals with minimal substrate preparation
- Engineered thermoplastics including XENOY®
- Polycarbonate • ABS • Acrylics • Non Sag

Replace welding, brazing, riveting and other mechanical fastening methods.



LORD® 201/19

Two Part Epoxy Adhesive

- Bonds unprepared metals with minimal substrate preparation
- Engineered thermoplastics including XENOY®
- Polycarbonate • ABS • Acrylics • Non Sag
- Time to Handling Strength, 12-16 min @ 75°F (24°C)

Replace welding, brazing, riveting and other mechanical fastening methods. Bonds a wide variety of substrates such as metals, ceramics and plastics; insensitive to minor deviations from correct mix ratio.

†variable cure rates available * Hi-temperature resistance: up to 400° F

See our complete line of LORD® products @ chemical-concepts.com



LORD® Structural Adhesives

LORD Adhesives



LORD® 310 A/B

Two Part Epoxy Adhesive

- Stone • High and low temp resistance; -40°F to 400°F
- Concrete • General Purpose
- Bare metal to HDU • Bare metal to wood

The ideal anchoring adhesive for stud mounting and bonding metal to porous (wood, concrete, stone).



LORD® 7542+ and 7545+

Two Part Urethane Adhesive

- HDU (Sign Foam) • PVC • Wood • Fiberglass
- Painted Metal • Polycarbonate

For use when bonding composites and dissimilar substrates.



LORD® 7550 A/C

Two Part Urethane Adhesive

- HDU • PVC • Wood • Fiberglass
- Painted Metal • Polycarbonate • UV resistant

Great for Trim Cap and plastic bonding.

†variable cure rates available * Hi-temperature resistance: up to 400° F

See our complete line of LORD® products @ chemical-concepts.com

400 Series

METAL BONDING AND CROSS BONDING METALS TO PLASTICS AND OTHER MATERIALS

The most versatile adhesive for the sign shop, the UL-approved 400 series can be used to replace welding, brazing, riveting and other mechanical fastening methods, outperforming these fasteners in harsh environments. For these reasons, the 400 series is frequently used for adding structural reinforcing members inside the sign box and building channel letters. Unleash your creativity and reduce your costs by using thinner gauge metals, pre-painted substrates and engineered plastics in various combinations.

PRODUCT	SPEED	WORK TIME (75°F/24°C)	HANDLINE TIME (75°F/24°C)	CURED COLOR	SUBSTRATES	
LORD 403/19	Fast	2-4 min	4-6 min	Light Green	<ul style="list-style-type: none"> Bare Metals – Aluminum, Steel, Stainless Steel Aluminium Composite Panel (ACP) / Aluminium Composite Material (ACM) Painted Metals Acrylic Sheet PETG Sheet 	<ul style="list-style-type: none"> Polycarbonate Sheet Polystyrene Foam Board Expanded PVC Foam Board Vinyl Laminate High Density Urethane Foam Dissimilar Materials (metal to plastic)
LORD 406/19	Medium	6-10 min	12-17 min	Light Green		
LORD 410/19	Slow	20-45 min	1-2 hrs	Light Green		

See **Signlok** page 8.



Scan the QR code to watch a **YouTube** video to learn how to build a sign box.

METAL FRAME ASSEMBLY



CHANNEL LETTER ASSEMBLY



OTHER USES



See **Signlok** page 8.

No-Mix Series

INDEFINITE OPEN TIME FOR LARGE APPLICATIONS OF METALS AND OTHER MATERIALS

No-Mix adhesive components, also known as “honeymoon” adhesives, are applied on the opposite mating surfaces of the substrates to be bonded. Curing does not start until the parts are brought together. This assembly technique is especially good for large surfaces with tight tolerances, such as mounting a sign face. These adhesives are to be used at bondline thicknesses 20 mils or less.



PRODUCT	SPEED	WORK TIME (75°F/24°C)	HANDLINE TIME (75°F/24°C)	CURED COLOR	SUBSTRATES	
LORD 201 (FLOWABLE)	Indefinite	6-8 min	12-16 min	Green	<ul style="list-style-type: none"> Acrylic Sheet Bare Metals – Aluminum, Steel, Stainless Steel Aluminium Composite Panel (ACP) / Aluminium Composite Material (ACM) Painted Metals 	<ul style="list-style-type: none"> PETG Sheet Polycarbonate Sheet Polystyrene Foam Board Expanded PVC Foam Board Vinyl Laminate High Density Urethane Foam
LORD 204 (NON-SAG)	Indefinite	6-8 min	12-16 min	Green		
MAXLOK™ T6 (HIGH PEEL)	Indefinite	6-8 min	12-16 min	Off-white		
LORD ACCELERATOR 4 (MUST BE USED ON ONE SIDE)		flashes in 1 min	N/A			



7500 Series

PLASTIC BONDING AND CROSS BONDING DIFFERENT TYPES OF PLASTICS AND OTHER MATERIALS

For an optically clear bonding, gap filling or bonding wood or other porous substrates, the 7500 series offers tough, flexible adhesives in a variety of speeds. The 7550 A/C is the perfect choice for bonding trimcap materials to polycarbonate faces.

PRODUCT	SPEED	WORK TIME (75°F/24°C)	HANDLINE TIME (75°F/24°C)	CURED COLOR	SUBSTRATES
LORD 7550 A/C	Fast	2-4 min	4-6 min	Optically Clear	<ul style="list-style-type: none"> Acrylic Sheet Polystyrene Foam Board
LORD 7542 A/B 	Medium	6-10 min	12-17 min	Brown	<ul style="list-style-type: none"> Painted Metals Expanded PVC Foam Board
LORD 7542 A/D 	Slow	20-45 min	1-2 hrs	Brown	<ul style="list-style-type: none"> Paper/Foam Board Vinyl Laminate PETG Sheet High Density Urethane Foam Polycarbonate Sheet Wood



Scan the QR code to watch a **YouTube** video to learn how to bond a channel letter face.

CHANNEL LETTER FACE ASSEMBLY

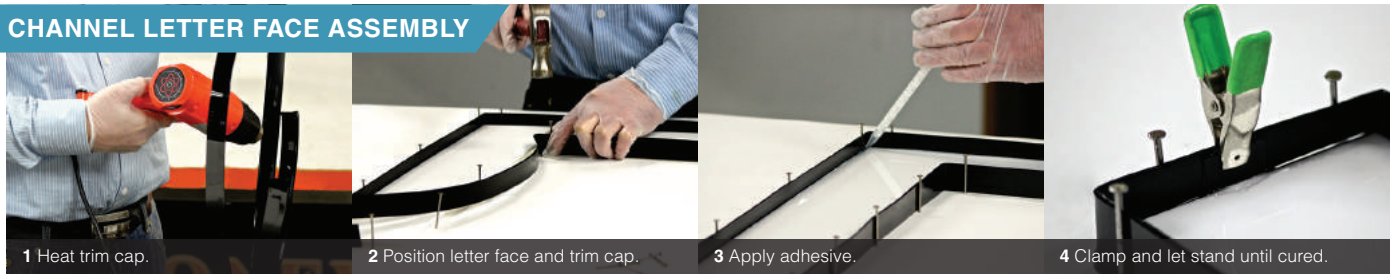

1 Heat trim cap.

2 Position letter face and trim cap.

3 Apply adhesive.

4 Clamp and let stand until cured.

**LORD STRUCTURAL ADHESIVES ARE AVAILABLE IN A CONVENIENT VARIETY OF SIZES
(IMAGES BELOW ARE NOT TO SCALE)**



CCH50G

MANUAL 50 ML CARTRIDGE
DISPENSING GUNS
Mixer - 190-620



DM200

MANUAL 200 ML CX CARTRIDGE
DISPENSING GUNS
Mixer - 160-824



535XSP

MANUAL 375 ML CARTRIDGE
DISPENSING GUNS
Mixer - MCQ08-24T



CCM380

MANUAL 405 ML CX CARTRIDGE
DISPENSING GUNS
Mixer - 160-824



ADHESIVES & CEMENTS



ACRYLIC SUBSTRATES

- 3

Non-flammable, water-thin, very fast set solvent cement for acrylics. Will also bond styrene, butyrate and polycarbonate to themselves.
Where not for sale in California (SCAQMD), please use SCIGRIP #4SC.
- 4

Non-flammable, water-thin, moderately fast set solvent cement for acrylics. Will also bond styrene, butyrate and polycarbonate to themselves.
Where not for sale in California (SCAQMD), please use SCIGRIP #4SC.
- 4SC[•]
NEW!

Water-thin, fast set solvent cement for acrylics. Will also bond styrene, butyrate and polycarbonate to themselves.
- 16[•]

Fast drying, high strength, medium bodied cement for acrylics. Will also bond styrene, butyrate, polycarbonate, other plastics and porous surfaces.
- 28[•]
KIT

Hand mixed three-component, reactive, high strength acrylic based adhesive with excellent weatherability. Mil Spec A-8576C Type II.
- 40[•]
KIT

Hand mixed two-component 20:1, reactive, high strength acrylic based adhesive provides "museum quality" water clear joints with excellent weatherability. Mil Spec A-8576C Type III.
Refrigeration Recommended
- 42[•]
50 ml
Cartridge

Two-component 10:1, reactive, high strength acrylic based adhesive provides "museum quality" water clear joints with excellent weatherability. Mil Spec A-8576C Type III.
Refrigeration Recommended
- 42[•]
230 ml
Cartridge

Two-component 10:1, reactive, high strength acrylic based adhesive provides "museum quality" water clear joints with excellent weatherability. Mil Spec A-8576C Type III.
Refrigeration Recommended
- 1802

Thin bodied, moderately fast set. For bonding acrylics, styrene, PVC, ABS and butyrate to themselves or each other.
- 3061[•]
VOC Free

Thinner for #40A (Acrylic Monomer).

VINYL, PVC, CPVC SUBSTRATES

- 66[•]

Thin syrup, fast curing, high strength. Instant contact strength. For flexible vinyl, urethane, wood, canvas, etc. Long working time.
- 1001

Thin syrup, slow set, rigid bond. For rigid or flexible vinyl to aluminum, glass, wood, etc.
- 1829

For many plastics and non-plastic materials, e.g., vinyls, acrylics, urethane, foam, polyester, wood, metal, etc.
- 1909

Medium syrup, fast set, flexible bond. For flexible vinyl, ABS, canvas, fabrics, acrylics, butyrate and polyurethane. Water resistant.
- 1910

Heavy syrup, slow set, solvent cement. For foamed, rigid and flexible PVC to themselves. Not for joining dissimilar materials.
- 2007

Water-thin, very fast set solvent cement. For foamed, rigid and flexible PVC to themselves and each other. Not for joining dissimilar materials.
- 4007[•]

Medium bodied syrup, very fast set, rigid bond. For rigid vinyl.
- 4052[•]

Medium syrup, fast set solvent cement. Multi-purpose for PVC, CPVC, ABS, styrene, nylon, foamed PVC, etc.
- 4784

Medium syrup, fast set, flexible bond. For flexible or rigid vinyl to itself or other materials such as fabrics, acrylics, butyrate and polyurethane. Weather resistant.





ADHESIVES & CEMENTS



POLYCARBONATE SUBSTRATES

55°
50 ml cartridge
VOC Free
Two-component 1:1, reactive urethane based adhesive for bonding polycarbonate, butyrate, ABS and PETG. Excellent UV light resistance. Does not alter the impact resistance of polycarbonate.

58°
50 ml cartridge
VOC Free
Two-component 1:1, reactive urethane based adhesive for bonding polycarbonate, butyrate, ABS and PETG. Excellent UV light resistance. Does not alter the impact resistance of polycarbonate.

STRUCTURAL ADHESIVES

10° Kit
LOW VOC
Two-component, high strength structural adhesive. High viscosity. Bonds PVC, acrylics, styrene, ABS, polycarbonates, etc. Same physical properties as #11.

11°
470 ml Cartridge
LOW VOC
Two-component, high strength, acrylic based adhesive packaged in a two-component cartridge for use with a mixing tip and dispensing gun. Same physical properties as #10. **Replaces #811.**

45°
43 ml & 400 ml Cartridge
LOW VOC
Two-component 4:1 high strength methacrylate structural adhesive. High viscosity. Bonds unprepared and corrosion resistant metals, composites and plastics.

UL 746C Approved

PPX5°
50 ml Cartridge
VOC Free
Two-component 10:1, high strength, acrylic based adhesive formulated for bonding low surface energy plastics. Packaged in a two-component cartridge for use with a mixing tip and dispensing gun.



STYRENE

4807°
LOW VOC
Medium syrup, fast set. For bonding styrene to itself.

ABS SUBSTRATES

1707
Medium syrup, fast set. Dries milky translucent. For cementing ABS ONLY!

2354
Water-thin, fast set solvent cement. For bonding ABS and styrene to themselves. Not for joining dissimilar materials.

4707°
LOW VOC
Heavy syrup, fast set, dries milky translucent. For cementing ABS ONLY! (Low VOC version of 1707).

CLEANER

57 Cleaner
Non-abrasive cleaner for acrylic and most other plastics.

ACCESSORIES



CCH50G
MANUAL 50 ML CARTRIDGE DISPENSING GUNS
Mixer - 190-620



535XSP
MANUAL 375 ML CARTRIDGE DISPENSING GUNS
Mixer - MCQ08-24T



CCM380
MANUAL 405 ML CX CARTRIDGE DISPENSING GUNS
Mixer - 160-824

• These products meet requirements of California South Coast Air Quality Management District (SCAQMD) Rule 1168.



Weld-On/SCIGRIP Acrylic Cements



Weld-On/SCIGRIP #16

- Fast drying, high strength, medium bodied cement for acrylics
- Working Time: 5-6 minutes • Fixture Time: 10 minutes
- Shelf Life: 2 years

Will also bond styrene, butyrate, polycarbonate, other plastics and porous surfaces.



Weld-On/SCIGRIP #45

- Two-component, 4:1 strength, methacrylate structural adhesive
- Working Time: 5-6 minutes • Fixture Time: 15 minutes
- Shelf Life: 2 years • UL 746C Approved

Bonds unprepared and corrosion resistant metals, composites and plastics.



Weld-On/SCIGRIP #4

- Water-thin, moderately fast set solvent cement for acrylics
- Working Time: 1-2 minutes • Fixture Time: 3 minutes
- Shelf Life: 2 years • Non-Flammable CLEAR

Will also bond styrene, butyrate and polycarbonate to themselves.



Weld-On/SCIGRIP #40

- Hand mixed two-component 20:1, reactive, high strength acrylic
- Working Time: 20 minutes • Fixture Time: 2 hours
- Shelf Life: 1 year • Refrigeration Recommended

Provides “museum quality” water clear joints with excellent weatherability.

See our complete line of Weld-On/SCIGRIP products @ chemical-concepts.com



Weld-On/SCIGRIP Acrylic Cements



Weld-On/SCIGRIP #10 Kit

- Two-component, high strength structural adhesive
- Working Time: 25 minutes • Fixture Time: 1 hour
- Shelf Life: 1 year • High viscosity • WHITE

Bonds PVC, acrylics, styrene, ABS, polycarbonates to steel, aluminum, etc. Same physical properties as #11.

Weld-On/SCIGRIP #11

- Two-component, high strength, acrylic based adhesive
- Working Time: 25 minutes • Fixture Time: 1 hour
- Shelf Life: 1.5 year • WHITE

Two-component cartridge for use with a mixing tip and dispensing gun. Same physical properties as #10.



Weld-On/SCIGRIP #55

- Two-component 1:1, reactive urethane based adhesive
- Working Time: 5-6 minutes • Fixture Time: 1-2 hours
- Shelf Life: 1 year • Excellent UV light resistance • CLEAR

For bonding polycarbonate, butyrate, ABS and PETG. Does not alter the impact resistance of polycarbonate



Weld-On/SCIGRIP #58

- Two-component 1:1, reactive urethane based adhesive
- Working Time: 2-3 minutes • Fixture Time: 20 minutes
- Shelf Life: 1 year • Excellent UV light resistance • CLEAR

For bonding polycarbonate, butyrate, ABS and PETG. Does not alter the impact resistance of polycarbonate

See our complete line of Weld-On/SCIGRIP products @ chemical-concepts.com



Potting and Encapsulating Applications



Electronics: Chem-Set[™] potting and encapsulating line provide a protective barrier against moisture and environmental contaminants.

- Low viscosity products allow for easy pouring and potting around complex parts
- Conductive technology for thermal management
- High durometer with low modulus technology is available to minimize CTW strain
- Excellent shock and vibration resistance
- Variety of both room temperature and heat curing materials
- Adhesion packages are available to obtain primerless adhesion to many substrates
- Withstand extreme temperatures from -55°C to 204°C or -67°C to 400°C



Flat Panel Display: Chem-Set[™] offers a series of optically clear silicones to help bond glass and plastics to flat panel and LCD displays.

- UV resistant
- Non-yellowing catalyst systems are available
- Pigmentable to provide contrast enhancement
- Various bonding strengths from removable/repairable to permanent
- Protects components from harsh environmental factors
- Gel interlayer for glare reduction



LED Video Display: Potting and encapsulating line provide a protective barrier against moisture and environmental contaminants.

- UL listed grades are available (See our UL Rating File Number QMFZ2.E205830)
- Encapsulants with high refractive indices are available to yield higher light outputs.
- Non-yellowing catalyst systems are available
- Self-bonding grades available
- Low viscosity flow easily around complex parts to minimize air entrapment
- Lower risk for delamination from CTE mismatch
- Withstand extreme temperatures from -55°C to 204°C or -67°C to 400°C
- Thermally conductive grades are available



LED Lighting: Temperature resistant, optically clear silicones can be applied over surface mount LEDs and are designed to be mixed with either diffusants or whitening agents if required.

- Higher refractive indexes to facilitate a brighter and longer lasting light
- Non-yellowing catalyst systems are available
- Low viscosity to flow around complex parts and minimize air entrapment
- Excellent thermal stability
- Self-bonding grades available.
- UL listed grades available (See our UL Rating File Number QMFZ2.E0005830)

See our potting and encapsulant products on page 18



LED Potting and Encapsulants

LEARN A NEW WAY TO PRODUCE “LED LIGHTING”

LED Potting and Encapsulants

- UV resistant
- Non-corrosive
- Odorless
- Moisture protection
- Self healing and repairable
- Room temperature cure
- Offered in side x side cartridges 50MLs to 1500MLs
- Operating temp -55°C to 204°C (-67°F to 400°F)

Chem-Set™

412 LED Compound



033 GEL



355



04



Color	Durometer	Ratio	Self Leveling	Gel Time
Applications: Electronics, Flat Panel Display, LED Video Display				
Optically Clear	40, Shore A	1.1	✓	28 min
Applications: Electronics, General Purpose, Healthcare, LED Video Display				
Optically Clear	45, Shore 00	1.1	✓	70 min
Applications: Electronics, Lighting, Power Supplies, Solar				
Black	45, Shore A	1.1	✓	140 min
Applications: Aerospace, Electronics, Power Supplies				
White	40, Shore A	10.1	✓	45 min



Adhesive Sealants

Acetoxy cure silicones

Acetoxy cure silicones have high elasticity and are extremely tough in extreme low and high temperature settings. Silicones also have the highest rated index for UV resistance, which is critical to many commercial and residential applications where sealant exposure is critical. Key characteristics include: non-yellowing, non-flammable, excellent weatherability, and resistance to mildew.



Bondaflex 100

General purpose, one-component, 100% RTV acetoxy silicone sealant.

- Colors: white, translucent, trans-white, glacier white, bone and cameo

Chem-Set™ RTV 4500

General purpose, one-component, 100% RTV acetoxy silicone sealant.

- Colors: clear, trans/charcoal, trans/blue, trans/gray, trans/white, trans/beige, trans/green, trans/rose, trans/brown, trans/earthtone, white, almond, taupe, cameo/biscuit, gray, orchid, mexican sand, sandbar, rock creek

Neutral cure silicones

Neutral cure silicones are in the same family tree as acetoxy silicones. While retaining those properties, neutral cures have added capabilities such as being non-corrosive, low odor, greater permanent flexibility and capacity for movement. Neutral cures offer a wider range of adhesion to common materials (plastic and masonry) without the user of a primer. This grouping of silicones offers particular formulas for Mult-Surface Adhesion, Self Leveling, High Temperature, Fast Curing, and All Weather Sealant.



Chem-Set™ RTV 7500

One-component, RTV oxime silicone sealant, low odor and non-corrosive.

- Colors: clear, white, black, aluminum, gray, bronze, almond

Sika AnchorFix-2

Two component, solvent and styrene free anchoring adhesive.

- Fixing close to free edges
- Versatile range of embedment depths
- Anchoring without expansion forces
- Fits standard caulk guns (26:1 thrust ratio)
- Extended working time

Must use with a good quality caulking gun. Minimum 18:1 thrust ratio.





Adhesive Sealants

Hybrid Sealants

Hybrids are silane-crosslinking organic polymers that combine properties typical of both silicone and polyurethane with the weathering resistance of silicones.

“Silicone on Steroids”



Chem-Set™ 75-AM Ultra Clear

- 2 times the bond strength of silicone -Lap shear 250-330 PSI
- 100% VOC HAPS/Compliant -75°F to 250°F (operating temp range)
- Shelf life 9 months • 24 tubes per case



Chem-Set™ MS-35 White

- Available in 10.3 standard caulking cartridge
- 2 times the bond strength of silicone -Lap shear 250-330 PSI
- 100% VOC HAPS/Compliant -75°F to 250°F (operating temp range)
- Shelf life 9 months • 24 tubes per case



LORD 7610DTM White

- Direct-to-metal single-component sealer & adhesive
- Durable - creates high strength bonds
- Temperature Resistant - can be applied at temperatures from -75° to +350°F (-59° to 177°C).
- Shelf life one year



Sikaflex 221 Polyurethane Construction Adhesive

- High strength polyurethane adhesive/sealant, non-sag, low odor, sandable and paintable
- Colors: white, grey and black



Chem-Set™ PB-3 Siliconized Acrylic Latex

- One-component, latex sealant
- Paintable, mildew resistant and non-yellowing
- Colors: clear, white, almond • Water clean up
- Polyurethane Sealant

See our complete line of adhesive sealants @ chemical-concepts.com



Epoxies/Acrylics



25ml



50ml



50ml



25ml



50ml



600ml

Chem-Set™ 605 Quick Set Acrylic

- 25ml or 50ml
- Exceptional bonds to non porous substrates
- Bonds plastics, metals, and many substrates

Chem-Set™ 607

Clear Structural Acrylic Adhesive. Crystal clear structural adhesive for assembly of plastic surfaces.

- UV stable with self-leveling liquid
- Minimal or no surface preparation
- Room temperature cured with short open time

Chem-Set™ 633 Gel Epoxy

- 25 ml, 50 ml or 400 ml
- High Viscosity
- Bonds to stone, wood and porous substrates

Chem-Set™ 633 LV Epoxy

- Available in 400ml and 600ml u-Tah cartridge which fits in standard caulking guns
- Low Viscosity
- 5 minute epoxy
- Great for rodding and laminating

All these products are available in bulk packaging (1 gallon and buckets)



Aerosols



Highest Available Strength!



Complete line of aerosols available!



Q320 Clear

Full quality aerosol line available in aerosol cans and canisters.

- Ideal for: Laminates to tables, Cabinets of all types, Drywall Insulation, MRP board and EPS

Contact Adhesives

- Q5000 High temperature strength solvent contact adhesive
- Q5200 Flammable contact adhesive, VOC Compliant in all states
- Q5500 Water born contact adhesive, VOC Compliant in all states

Adhesive Remover

Q8200 Adhesive Remover/Gun & Hose Cleaner

Besides being an adhesive remover, can be used to clean guns and hoses

Pressure Sensitive Adhesives

- Q6000 High solids solvent pressure sensitive adhesive
- Q6200 Flammable pressure sensitive adhesive
VOC compliant in all states
- Q7200 Expanded polystyrene adhesive



See our complete line of products @ chemical-concepts.com



High Bond Tapes

Chem-Set™ Solutions for the Signage Industry

72 YD ROLLS

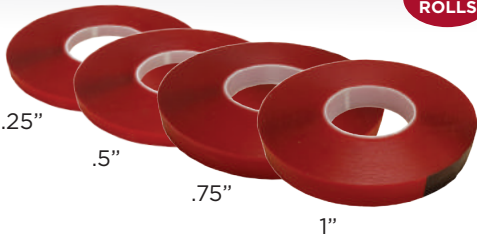

Chem-Set™ VST 3025 10 mil (.010") **CLEAR**
DC Acrylic Foam Poly Paper Liner.

- High tensile strength
- Moisture and solvent resistant
- Exceptional dynamic shear properties in hot and cold temps

COMPARE TO: 3M VHD 4905 and 4910

36 YD ROLLS

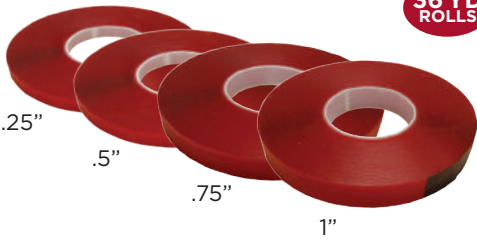

Chem-Set™ VST 3050 20 mil (.020") **CLEAR**
DC Acrylic Foam Poly Paper Liner.

- High tensile strength
- Moisture and solvent resistant
- Exceptional dynamic shear properties in hot and cold temps

COMPARE TO: 3M VHD 4905 and 4910

36 YD ROLLS

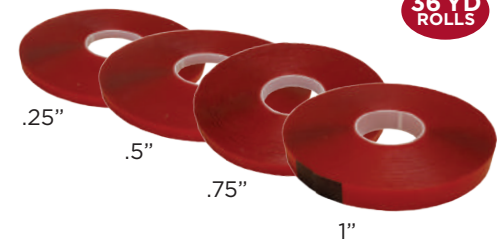

Chem-Set™ VST 6100 40 mil (.040") **CLEAR**
Transparent tape with an acrylic core.

- High tensile strength
- Moisture and solvent resistant
- Exceptional dynamic shear properties in hot and cold temps

COMPARE TO: 3M VHD 4905 and 4910

36 YD ROLLS

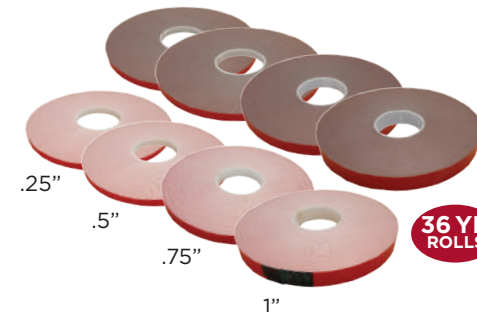

Chem-Set™ VST 6120 47 mil (.047) **GRAY or WHITE**
DC Acrylic Foam Poly Paper Liner.

- High tensile strength
- Moisture and solvent resistant
- Exceptional dynamic shear properties in hot and cold temps

See our complete line of Tapes @ chemical-concepts.com



High Bond Tapes

Solutions for the Signage Industry

Optically Clear Bonding



11 YD ROLLS

tesa® 7054 ACXplus 20 mil (.020") **CLEAR**

- Transparent acrylic core tape
- Perfect for bonding of transparent materials such as glass or acrylic
- High immediate tack and peel adhesion
- Used for: Sign manufacturing, Deco glass panels, Partition walls

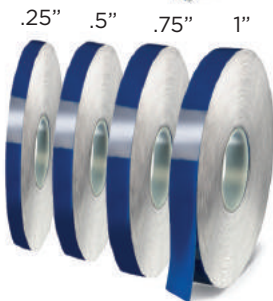

11 YD ROLLS

tesa® 7055 ACXplus 40 mil (.040") **CLEAR**

- Transparent acrylic core tape
- Perfect for bonding of transparent materials such as glass or acrylic
- Characterized by its bonding power, stress dissipation and its temperature and weather resistance
- Used for: Sign manufacturing, Deco glass panels, Partition walls



11 YD ROLLS

tesa® 7063 ACXplus 32 mil (.032") **BLACK**

- Black tackified acrylic core tape
- Tackified for bonding of "hard-to-bond materials"
- Great expansion/contraction capabilities
- High immediate tack and peel adhesion
- Used for: Painted signage, low surface energy surfaces (PE, PP, PVC)



11 YD ROLLS

tesa® 7065 ACXplus 47 mil (.047") **BLACK**

- Black tackified acrylic core tape
- Tackified for bonding of "hard-to-bond materials"
- Great expansion/contraction capabilities
- High immediate tack and peel adhesion
- Used for: Painted signage, low surface energy surfaces (PE, PP, PVC)



55 YD ROLLS

tesa® 61010 8 mil (.008") **CLEAR**

- Clear permanent mounting tape
- Used for: Interior signage

See our complete line of Tesa® Tapes @ chemical-concepts.com



General Assembly & Masking Tapes



Solutions for the Signage Industry

1"

2"

60 YD ROLLS

tesa® 4970 Banner Tape

8.9 mil (.0089")

- White PVC-film acrylic tape
- Excellent combination of high tack and immediate adhesion
- Great for rough surfaces
- Strong adhesive power and humidity resistance



.75"

1"

2"

55 YD ROLLS

tesa® 4334 Precision Mask

3.5 mil (.0035")

- Yellow precision masking tape
- Suitable for precise applications
- Guarantees very sharp-edged finishing
- Suitable for delicate surfaces



.75"

1"

1.5"

2"

60 YD ROLLS

tesa® 53120 General Purpose Mask

5.2 mil (.0052")

- Creme creped paper masking tape
- Cost efficient
- Good for general purpose bonding, molding, sealing and surface protection
- Adheres to a variety of surfaces

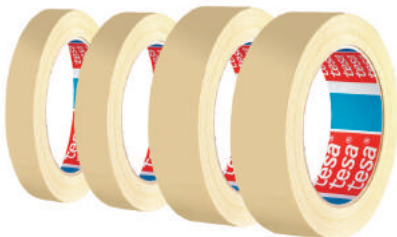

1"

2"

72 YD ROLLS

tesa® 50600 Powder-Coating Tape

3 mil (.003")

- Distinctive green color
- Conformable to most surfaces
- Temperature resistant up to 220°C / 428°F
- Provides sharp paint edges



See our complete line of Tesa® Tapes @ chemical-concepts.com



Foam Tapes



36 YD ROLLS

Double Coated Foam Tape

1/16" Thick

- Used for mounting and joining nameplates, signs, small die cast parts, mirrors, maps, etc
- Excellent quick-stick sealing with high shear properties
- Good resistance to humidity, mild acids, oil and grease



72 YD ROLLS

Double Coated Foam Tape

1/32" Thick

- Used for mounting and joining nameplates, signs, small die cast parts, mirrors, maps, etc
- Excellent quick-stick sealing with high shear properties
- Good resistance to humidity, mild acids, oil and grease



55 YD ROLLS

tesa® 62934 Double Sided PE Foam Tape

1/32" Thick

- Versatile adhesive for high immediate adhesion
- UV, water, aging and cold shock resistant
- Specifically designed for rough surfaces and mounting of parts with gaps

See our complete line of Foam Tapes @ chemical-concepts.com



Tape Information

Panel and Letter Mounting



For mounting large sheets of common materials such as Dibond, Reynobond, PMMA¹, Aluminum ...

Recommended tesa® ACX^{plus} Tapes for Optically Clear Bonding:

tesa® 7054 ACX^{plus}, tesa® 7055 ACX^{plus}

Bonding Translucent Materials

- Acrylic core tape with very high transparency
- Available in two different thicknesses: 20mil and 40mil
- Very high initial and final bonding strength
- Compensates for thermal expansion of dissimilar materials
- Water and vapor tight, chemical resistant, and no yellowing, even after exposure to UV² light and outdoor elements
- ➔ First choice for mounting translucent materials

Recommended tesa® ACX^{plus} Tapes for Hard-to-Bond Substrates:

tesa® 7063 ACX^{plus}, tesa® 7065 ACX^{plus}

Hard-to-Bond Substrates

- Black acrylic core tape
- Bonding lower energy surfaces
- Bonding powder-coated surfaces
- Temperature and weather resistant
- Compensates for thermal expansion of dissimilar materials
- Available in two thickness: 32mil and 47mil

LED³ Mounting



For permanent bonding of LEDs to common surfaces such as Dibond, Reynobond, PMMA, Aluminum ...

Recommended tesa Tape for LED Mounting:

tesa® 62934

LED Mounting Tape

- High ultimate adhesive strength for secure bonding performance
- High-temperature resistance
- UV, water, aging, and cold shock resistant
- ➔ Specially-designed for mounting LEDs

Additional Recommended tesa Tapes for LED Mounting:

tesa® 7054 ACX^{plus}, tesa® 7055 ACX^{plus}

- Acrylic core tape with very high transparency
- Available in two different thicknesses: 20mil and 40mil
- Very high initial and final bonding strength
- Compensates for thermal expansion of dissimilar materials
- Water and vapor tight, chemical resistant, and no yellowing, even after exposure to UV light and outdoor elements
- ➔ For high-demand LED applications and enhanced security

¹ PMMA - polymethyl-methacrylate ² UV - ultraviolet ³ LED - light emitting diode



Tape Information

General Assembly



For metal and plastic parts with narrow constructive gaps

Recommended tesa Film Tapes:

tesa® 61010, tesa® 4970

Filmic Mounting Tapes

- Very good bonding performance, even on critical surfaces
- Excellent holding power at elevated temperatures
- Strong adhesion power and humidity resistance
- **tesa® 61010** when transparency is needed
- **tesa® 4970** for superior initial tack and slightly rough surfaces

Recommended tesa Foam Tape:

tesa® 62934

Foam Mounting Tape

- Versatile adhesive for high immediate adhesion on numerous substrates
- High initial and ultimate adhesion level
- UV, water, aging, and cold shock resistant
- Specially-designed for rough surfaces and mounting of parts with gaps

Masking

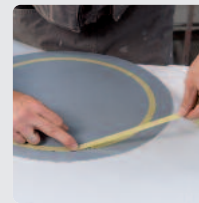
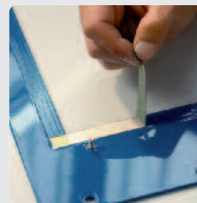
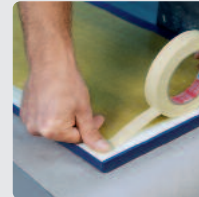
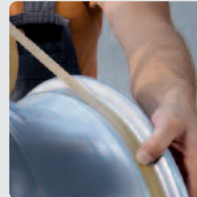

tesa® 4309 High-Temperature Masking Tape

- Masking paint jobs with oven drying up to 120°C / 248°F
- Resistant to wet sanding
- Removable without leaving residues
- Specially-designed for oven drying processes and applications where a high adhesion level is needed

tesa® 53120 PV1 General-Purpose Masking Tape

- Suitable for general-purpose applications
- For bundling and protecting during production, storage, and transportation

tesa® 4334 Precision Mask

- Suitable for precise applications
- Guarantees very sharp-edged finishing
- Suitable for delicate surfaces
- Also suitable for all applications where residue-free removability, even after a long period, is needed

tesa® 4174 Fine-Line Masking Tape

- Specially-designed for two-tone applications with subsequent oven drying
- Flexible; no shrinkage
- Very good conformability to irregular shapes
- Outstanding workability in combination with its high performance, making it the first choice for all curved applications

tesa® 50600 Powder-Coating Tape

- Distinctive green color
- Conformable to most surfaces
- Temperature resistant up to 220°C / 428°F
- Provides sharp paint edges
- Also available on liner
- The solution for masking during powder coating processes



Tape Information

tesa® ACX^{plus} - Permanent, High Bond Mounting

Product	Backing	Thickness without liner [µm / mils]	Adhesive	Color	Steel		PMMA*		Aluminum		Glass	
					72 hours		72 hours		72 hours		72 hours	
					N/cm	oz/inch	N/cm	oz/inch	N/cm	oz/inch	N/cm	oz/inch
tesa® 7054	acrylic	500 / 20	pure acrylic	clear	19.0	173.6	12.0	109.6	19.0	173.6	17.0	155.3
tesa® 7055	acrylic	1000 / 40	pure acrylic	clear	24.0	219.3	17.0	155.3	24.0	219.3	24.0	219.3
tesa® 7063	acrylic	800 / 32	tackified acrylic	black	30.0	274.1	27.0	246.7	32.0	292.4	32.0	292.4
tesa® 7065	acrylic	1200 / 47	tackified acrylic	black	40.0	365.4	35.0	319.8	35.0	319.8	36.0	328.9

*polymethyl-methacrylate

Mounting

Product	Backing	Thickness without liner [µm / mils]	Adhesive	Color	Steel		PC		Aluminum		PVC	
					14 days		14 days		14 days		14 days	
					N/cm	oz/inch	N/cm	oz/inch	N/cm	oz/inch	N/cm	oz/inch
tesa® 62934	PE-foam	800 / 32	tackified acrylic	black	17.0	155.3	17.0	155.3	17.0	155.3	17.0	155.3
tesa® 61010 PV4	PET	205 / 8	tackified acrylic	clear	14.0	127.9	13.4	122.4	12.6	115.1	12.8	116.9
tesa® 4970	PVC	240 / 9.5	tackified acrylic	white	14.8	135.2	13.8	135.2	12.4	113.3	13.5	123.3
tesa® 4985	n/a	50 / 2	tackified acrylic	clear	11.1	101.4	9.7	88.6	10.0	91.4	9.4	85.9
tesa® 4985 PV9	n/a	50 / 2	tackified acrylic	clear	11.1	101.4	9.7	88.6	10.0	91.4	9.4	85.9
tesa® 6013	n/a	n/a	n/a	n/a	n/a	n/a	n/a	n/a	n/a	n/a	n/a	n/a

Masking

Product	Backing	Thickness [µm / mils]	Adhesive	Color	Adhesion to Steel		Tensile Strength		Temperature Resistance [1 hour]
					N/cm	lbs/inch	N/cm	lbs/inch	
tesa® 53120 PV1	creped paper	132 / 5.2	natural rubber	cream	3.4	31.1	36.8	21.0	50°C / 122°F
tesa® 4334	flat paper	90 / 3.5	acrylic	yellow	1.9	17.4	25.0	14.3	60°C / 140°F
tesa® 4309	creped paper	170 / 6.7	natural rubber	brown	3.5	32.0	47.0	26.8	120°C / 248°F
tesa® 4174	PVC	110 / 4.3	natural rubber	olive	3.4	31.1	25.0	14.3	150°C / 302°F
tesa® 50600	PET	80 / 3.2	silicone	green	4.0	36.5	>40.0	>23.0	220°C / 428°F
tesa® 4848 PV1	PE	48 / 1.9	acrylic	clear	0.8	7.3	12.0	6.9	60°C / 140°F

tesa products prove their impressive quality day in day out in demanding conditions and are regularly subjected to strict controls. All information and recommendations are provided to the best of our knowledge on the basis of our practical experience. Nevertheless, tesa tape, inc. can make no warranties, expressed or implied, including, but not limited to any implied warranty or merchantability or fitness for a particular purpose. The user, therefore, is responsible for determining whether the tesa product is fit for a particular purpose and suitable for the user's method of application. If you are in any doubt, our technical support staff will be glad to advise you.



Sanders, Abrasives and Pads



11" Dual Action Electric General Sander

- Runs 1700 "orbits" per minute
- Smooth, hand-polish action
- 11" drive pad utilizing hook and loop sandpaper
- Consistent, uniform finish
- Mixed grit types / semi-friable aluminum oxide
- c-wt paper backing

FEATURES

- Features**
- Heavy-duty ball bearing capacitor motor
 - No gears to grind or strip out
 - No armature winding to burn out
 - No carbon brushes to burn out
 - Exclusive removal shaft system
 - Sands, polishes and finishes

SPECIFICATIONS

- Specifications**
- Weight.....18 lbs.
 - Overall height.....10in.
 - Amps..... 2.3@110v, 1.2@220v
 - RPM..... 1,77@11v
 - Moto..... 110v/220v
 - Housing.....heavy-duty aluminum

11.25-in. Sanding Discs Blue for Gem Sander

Abrasives

Sanding Pads

GREAT QUALITY!

Maroon and Gray Scuff

6"

PSA & Hook and Loop

5"

PSA & Hook and Loop

- Scuff Pads
- Reasonably Priced!
- PSA and Hook and Loop
- Assortment of Grits: 80, 120, 180, 220, 320



1950 SiaSpeed Siafast H/L Paper Discs Series

The versatile all-round product 1950 siaspeed is specially designed for high stock removal rates, perfect surface quality and long life in applications such as the surface treatment of body filler, primer filler, lacquers and paints.



5" x 5 H



6" x 15 H



6" x 9 H



5" x 9 H
Festool



5" x NH
Best



6" x NH

See our complete line of sanders, abrasives and pads @ chemical-concepts.com



Hot Melts

Chem-Set™ Hot Melt Adhesives



725R10, 735R10, 711R10

- General purpose for porous and non-porous materials
- Use on metals, ceramics, coated papers, non-porous materials
- Sizes: 1/2" x 10", 5/8" x 2"
- Colors: 725R10-Translucent, 735R10-Amber

725R10: 1/2" x 4"	1/2" x 10"	
5/8" x 4"	5/8" x 10"	5/8" x 15"
3/4" x 2.5"	3/4" x 10"	
5/16" x 4"	5/16" x 10"	
1" x 3"		

735R10: 1/2" x 10"	
5/8" x 10"	5/8" x 2"
3/4" x 2.5"	
1" x 3"	

711R10: 1/2" x 10"	1/2" x 15"
5/8" x 10"	
3/4" x 2.5"	
1" x 3"	



HM612

- For use with CCH220 gun
- Full cure in 5 minutes • Will not get brittle
- One stick covers 4 linear feet
- Newest technology in hot melts using acrylic resins for stronger bonds
- Used for channel letters and metal bonding (see page 5)



Other formulations available—call for more information

Warning: Contact with skin can cause severe burns!

See our complete line of hot melt adhesives @ chemical-concepts.com



Dispense Guns and Mixers

Chem-Set™ We stock Manual & Pneumatic Adhesive Dispense Guns from Cox, Newborn, Sulzer and Albion.











Dispense Gun	Recommended Mixer
 <p>CCH50G 50 ml</p> <ul style="list-style-type: none"> • For use with 50 ml cartridges • Easily converts to 1:1, 2:1, 4:1, 10:1 • Impact resistant hardened plastic body is lightweight and extremely durable • No-Drip design with an integrated pre-release system 	 <p>TAH 190-620 Static Mixing Nozzle</p>
 <p>DK Converter 50 ml</p> <ul style="list-style-type: none"> • Caulk Gun Adapter for use inside caulk gun • For use with 50 ml cartridges • Caulk gun adapter for use inside caulk gun: 1:1, 2:1, 4:1, 10:1 • Converts 50ml dual cartridges for use in standard 1/10th gal. guns <p><i>* Pictured inside 250 caulk gun</i></p>	 <p>TAH 190-620 Static Mixing Nozzle</p>
 <p>535XSP 375 ml</p> <ul style="list-style-type: none"> • 26:1 Thrust ratio • Extra durable, heat treated piston rod • Precision sintered friction plate • Easy release star-burst reverse gripping plate • Easily converts to 300ml x 300ml, 300ml x 150ml, 300ml x 75ml 	 <p>MCQ 08-24T Static Mixing Nozzle</p>
 <p>M380 404 ml</p> <ul style="list-style-type: none"> • 18:1 Thrust ratio • For use with coaxial cartridges • Available gun ratios: 1:1, 2:1, 4:1, 10:1 • Catch Plate - Sintered Steel • All component replaceable parts 	 <p>TAH 160-824 Static Mixing Nozzle</p>

See our complete line of Chem-set™ Dispense Guns @ chemical-concepts.com



Dispense Guns and Mixers

Chem-Set™ We stock Manual & Pneumatic Adhesive Dispense Guns from Cox, Newborn, Sulzer and Albion.

Dispense Gun	Recommended Mixer
 <p>830A30 375 ml</p> <ul style="list-style-type: none"> • Multi ratio pneumatic 2-part adhesive dispensing gun • 300ml x 300ml, 300ml x 150ml, 300ml x 75ml, 150ml x 150ml • Nominal thrust, 490 lbs. @ 100psi 2.5" Cylinders 	 <p>MCQ 08-24T Static Mixing Nozzle</p>
 <p>520 GUN 225 ml</p> <ul style="list-style-type: none"> • 18:1 Thrust ratio • Easily converts to 75 ml, 150ml, 180ml • Extra durable, heat treated piston rod • Precision sintered friction plate • Easy release star-burst reverse gripping plate 	 <p>TAH 160-824 Static Mixing Nozzle</p>
 <p>250 High Thrust Caulk Gun</p> <ul style="list-style-type: none"> • 18:1 thrust ratio • For use with one part adhesives/sealants in 1/10 gal cartridges • Revolving barrel 	 <p>Silicone Nozzle (4") Seaming Adhesive Tip</p>
 <p>VR200XSP</p> <ul style="list-style-type: none"> • 26:1 Thrust ratio • For use with 220ml mixpac and TAH cartridges • Easily converts to 1:1, 2:1, 4:1 and 10:1 • Precision sintered friction plate 	 <p>TAH 160-624 Static Mixing Nozzle</p>
 <p>DM200 200 ml</p> <ul style="list-style-type: none"> • Torsion free construction • Integrated pressure relief • No dripping 	 <p>TAH 190-620 Static Mixing Nozzle</p>

See our complete line of Chem-set™ Dispense Guns @ chemical-concepts.com



Bonding Fasteners

Chem-Set™ **KEEP-NUT™** by ™

Installs in 2 EASY steps!

- **Drill 1/4" hole**
- **Press in KEEP-NUT™!**



Press In Self-Anchoring Threaded Inserts

- **KEEP-NUT™** is a revolutionary press-in insert with mechanical anchoring to create threaded seat on panels, wall-mounting signs, fixtures, wall coverings, ventilated facades, décor, and much more.
- **KEEP-NUT™** is manufactured in stainless steel and it's made of a threaded bush with a set of elastic crowns and a plastic ring for holding the complete set of parts.

Tested and works with 1" Sintra PVC Board "up to 90 lbs"

- Usable with panels spanning a variety of sizes – including fairly thin panels (down to 6.5mm or 1/4")
- 90lbs. pull-out force for PVC board (other solid surfaces can have up to 562lbs. pull-out force!)
- Easily installed in the smallest of fixtures/signs
- **NO ADHESIVES = LESS MESS!**
- "No-through" threading of the internal bushing to prevent over tightening



Keep-Nut™ Setting Tool - 1/4-20 Thread

The Keep-Nut Setting Tool or Insertion Tool is used to insert the Keep-Nut into the pre-drilled hole created by your CNC or Manual Bit.



Keep-Nut™ Go/No-Go Gauge

The Keep-Nut Go/No Go Gauge is used to test the drilled diameter and depth of the Keep-Nut hole.



Keep-Nut™ 11.8mm Drill Bit w/ Stop Collar

Comes with an adjustable stop collar to easily and accurately drill precise depth holes.



Bonding Fasteners

Chem-Set™

No Drill FASTENERS

No drilling or welding! Mounts using structural adhesives

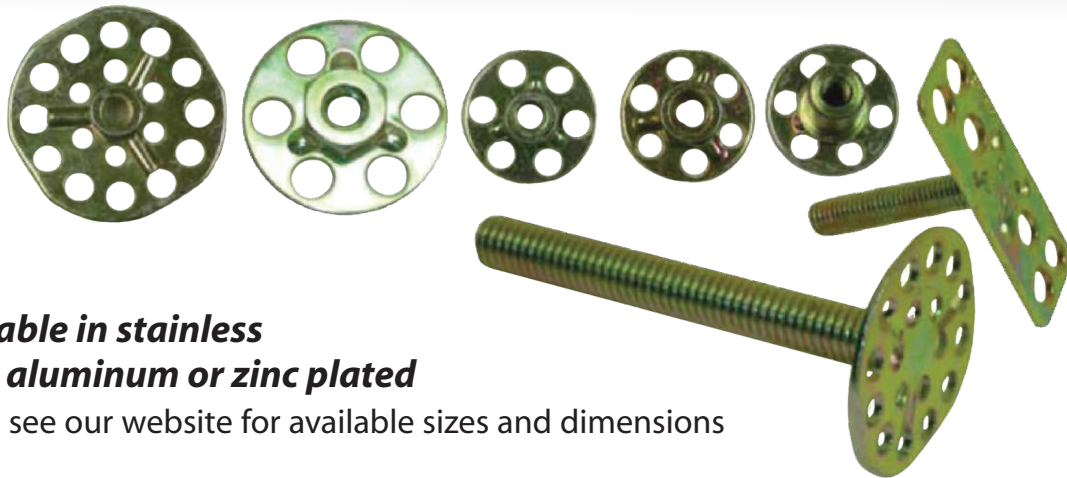

Available in stainless steel, aluminum or zinc plated

Please see our website for available sizes and dimensions

Use **Chem-Set™ No Drill** Bonding Fastener to replace rivets, tapes and welds.

- Bonds with metals, plastics, wood, composites, stone.
- Available in Zinc plated, stainless steel, Trivalent Zinc Coatings as well as Nano Plating on Mild Steel Parts
- No drilling or taping





Bonding Fasteners

TYPE M1 MALE BOLT STUDS

Available in both imperial and metric threads in a variety of lengths.

Available in plated steel and stainless steel
(plating meets European standards)

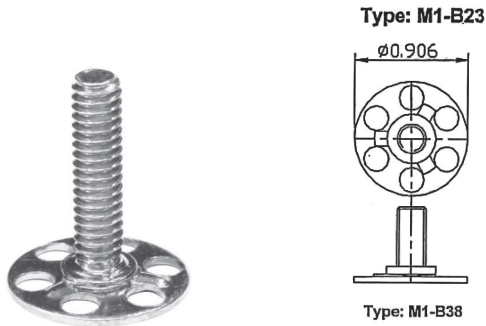

Type: M1-B23

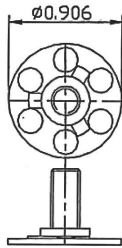

M1-B23 (23MM / 0.91") ROUND

THREAD SIZE	COMMON LENGTHS			
1/4-20 UNC	.75"	1"	1.5"	2"
10/32 UNF	.75"	1"	1.25"	2"

*Additional Threads and Thread Lengths Available

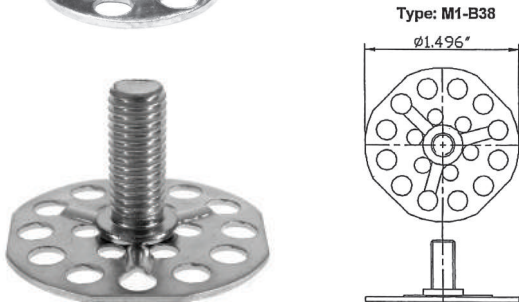

Type: M1-B38

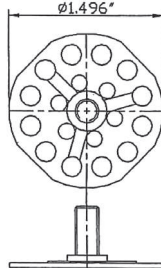

M1-B38 (38MM / 1.50") ROUND

THREAD SIZE	COMMON LENGTHS							
1/4-20 UNC	.675"	.75"	1"	1.25"	1.5"	2"	2.5"	3"
10/32 UNF	.675"	.75"	1"	1.25"	2"			
3/8 UNC	1.5"	2"	2.5"	3"				

*Additional Threads and Thread Lengths Available

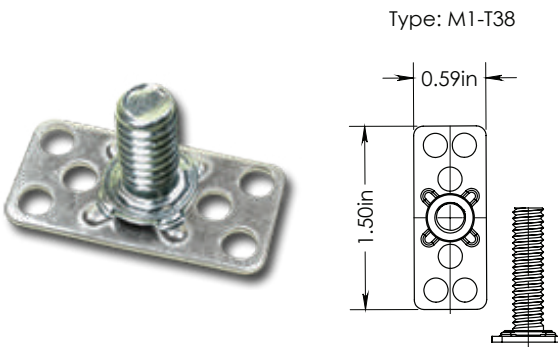

Type: M1-T38

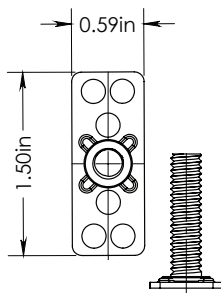

M1-T38 (38MM / 1.50") RECTANGULAR

THREAD SIZE	COMMON LENGTHS			
1/4-20 UNC	.75"	1"	1.5"	2"
10/32 UNF	.75"	1"	1.25"	2"

*Additional Threads and Thread Lengths Available



Bonding Fasteners

TYPE F1 HEX NUTS

F1 - Female Hex Nuts securely mounted on a variety of perforated baseplates.

Available in both Inch and metric threads.

	<p>Type: F1-B23</p>	<p>F1-B23 (23MM / 0.91") ROUND</p> <p>THREAD SIZE*</p> <p>1/4 UNC 5/16 UNC</p>
	<p>Type: F1-B38</p>	<p>F1-B38 (38MM / 1.50") ROUND</p> <p>THREAD SIZE*</p> <p>1/2 UNC 10/32 UNF 5/16 UNC 1/4 UNC 3/8 UNC</p>
	<p>Type: F1-SB30</p>	<p>F1-SB30 (30MM / 1.18") SQUARE</p> <p>THREAD SIZE*</p> <p>1/4 UNC 5/16 UNC</p>
	<p>Type: F1-SB50</p>	<p>F1-SB50 (50MM / 1.97") SQUARE</p> <p>THREAD SIZE*</p> <p>1/2 UNC 10/32 UNF 5/16 UNC 1/4 UNC 3/8 UNC</p>
	<p>Type: F1-T38</p>	<p>F1-T38 (38MMX15MM/ 1.50"X.59") RECTANGLE</p> <p>THREAD SIZE*</p> <p>1/4 UNC 5/16 UNC</p>

*Additional Threads Available

Most popular bonding fasteners and sizes illustrated. See website for our complete line of fasteners @ chemical-concepts.com



Bonding Fasteners

TYPE F2 FEMALE COLLARS

F2 - Female Threaded Collars of various lengths mounted on a variety of baseplates.

Available in both imperial and metric threads.



Type: F2-B23



F2-B23 (23MM / 0.91") ROUND

THREAD SIZE* COMMON LENGTHS*

1/4 UNC	.375"	.5"
---------	-------	-----



Type: F2-B38

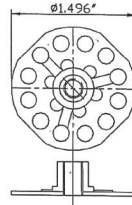

F2-B38 (38MM / 1.50") ROUND

THREAD SIZE* COMMON LENGTHS*

1/4 UNC	.375"	.5"	.75"	1"
10/32 UNF	.375"	.5"	.75"	1"
3/8 UNC	.375"	.5"	.75"	1"
5/16 UNC	.375"	.5"	.75"	1"



Type: F2-SB30

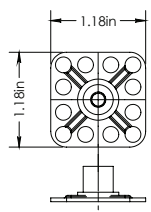

F2-SB30 (38MM / 1.50") SQUARE

THREAD SIZE* COMMON LENGTHS*

1/4 UNC	.375"	.5"	.75"	1"
10/32 UNF	.375"	.5"	.75"	1"



Type: F2-SB50

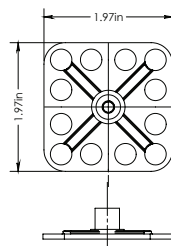

F2-SB50 (50MM / 1.97") SQUARE

THREAD SIZE* COMMON LENGTHS*

1/4 UNC	.375"	.5"	.75"	1"
10/32 UNF	.375"	.5"	.75"	1"
3/8 UNC	.375"	.5"	.75"	1"
5/16 UNC	.375"	.5"	.75"	1"



Type: F2-T38

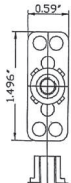

F2-T38 (38MMX15MM / 1.50"X.59") RECTANGLE

THREAD SIZE* COMMON LENGTHS*

1/4 UNC	.375"	.5"	.75"	1"
10/32 UNF	.375"	.5"	.75"	1"

*Additional Threads and Thread Lengths Available

Most popular bonding fasteners and sizes illustrated. See website for our complete line of fasteners @ Chemical-concepts.com



Bonding Fasteners

SPECIALTY ITEMS

Available in both Inch and metric threads.

Type: T38 FLAT

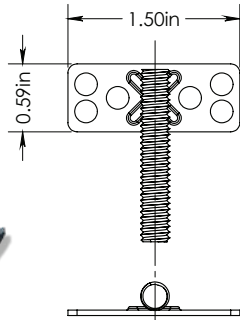

M1-T38 (38MM / 0.90") RECTANGULAR

THREAD SIZE	COMMON LENGTHS
1/4 UNC	.675" .75" 1" 1.25" 1.5" 2" 2.5" 3"
10/32 UNF	.675" .75" 1" 1.25" 2"
3/8 UNC	1.5" 2" 2.5" 3"

*Additional Threads and Thread Lengths Available

Type: M1-HP44

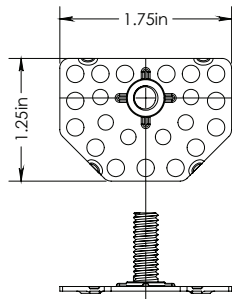

M1-HP44

THREAD SIZE	COMMON LENGTHS
1/4 UNC	.675" .75" 1" 1.25" 1.5" 2" 2.5" 3"
10/32 UNF	.675" .75" 1" 1.25" 2"
3/8 UNC	1.5" 2" 2.5" 3"

*Additional Threads and Thread Lengths Available

Type: M4-RB38

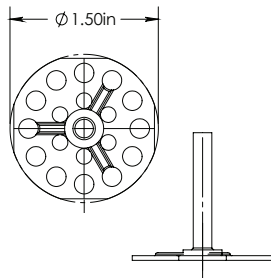

M4-38

THREAD SIZE	COMMON LENGTHS
N/A	N/A

*No Threads Available. For Insulation Only.

Type: M7-SB32

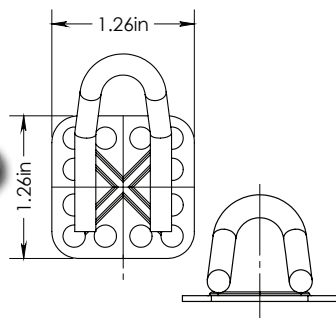

M7-SB32

THREAD SIZE	COMMON LENGTHS
N/A	N/A

*Use As Tie Downs



410 Pike Road • Huntingdon Valley, PA 19006

TOLL FREE: 800.220.1966

Phone: 267.684.1038 • Fax: 215.357.2754 • Email: sales@chemical-concepts.com

chemical-concepts.com