

Applications: metal quick fastening system for panels and coverings by pressing, removal by panel traction

Assembly: on structure by screwing, gluing, riveting

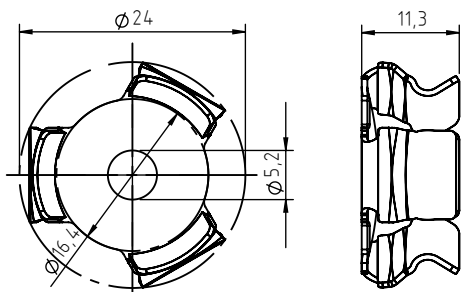

Female



code	material	traction release
FC-01-FE.51	inox 316	min 7kg
FC-01-FE.53	inox 301	min 10kg

Male

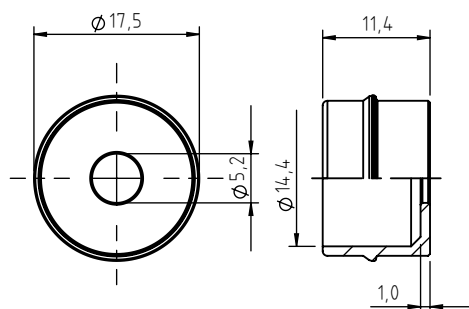

code	material
FC-01-MA.51	inox 316
FC-01-MA.50	inox 303

Values and dimensions are indicative and not binding - dimensions expressed in mm.



Accessories:

FC-00-CE.50 centering device



FC-00-LE.12 releave lever



Application example:
Built-in FAST-CON®

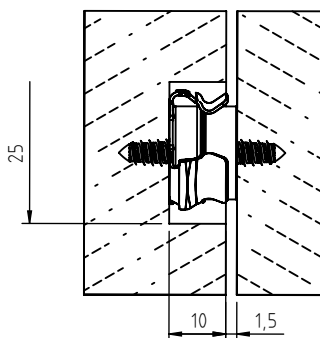

FAST-CON® flush installation

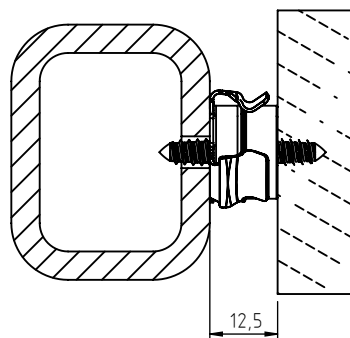

NOTA BENE: For installation guide, contact the Specialinsert® tech/sales office or refer to the catalogue at www.specialinsert.it/en

SPECIALINSERT® COMMITS ITSELF TO CONTINUOUSLY IMPROVE ITS PRODUCTS. IT RESERVES THE RIGHT TO CHANGE THEIR TECHNICAL AND STRUCTURAL CHARACTERISTICS WITHOUT PRIOR NOTICE. ALL RIGHTS ARE RESERVED AND THE DUPLICATE, EVEN PARTIAL OF THESE DOCUMENTS, AS WELL AS ITS DISTRIBUTION TO THIRD PARTIES ARE FORBIDDEN, UNLESS OTHERWISE AND EXPRESSLY AUTHORIZED BY SPECIALINSERT®.