



chemical-concepts.com

800.220.1966

410 Pike Road • Huntingdon Valley, PA 19006

Araldite® industrial adhesives

Adhesives technology



User's guide

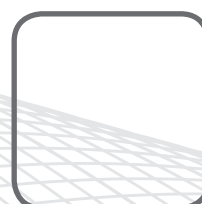
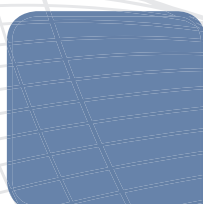
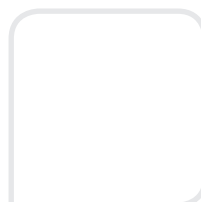



Table of contents

Adhesives technology	4
1-1 Introduction	4
A few words about adhesives	4
Huntsman industrial adhesives	5
Designing to bond	5
1-2 Assessment of bonding	6
Advantages of adhesive bonding	6
Limitations	9
Adhesive types and main characteristics	10
1-3 Designing a bonded joint	12
Loading conditions	12
Determination of simple lap joints dimensions	20
Durability of a bonded joint	22
Bonding process essentials	24



Adhesives technology

1-1 Introduction

Just about every industrial item produced is composed of components which have to be assembled together. Mechanical fasteners such as screws, rivets or spot welds are frequently used.

However, engineers now often choose to use adhesive bonding. This assembly technique is well proven and capable of replacing or supplementing mechanical fastening methods and can provide some advantages which include:

- > Outstanding lap shear strength and peel strength
- > Reduced component and/or assembly costs
- > Improved product performance and durability
- > Greater design freedom
- > Less finishing operations



A few words about adhesives

This guide is designed to help engineers overcome the reservations they may sometimes have about adhesives. It includes a survey of modern adhesives and shows how joints should be designed and pretreated in order to make the best use of adhesive bonding. This guide has roots going back to the days when adhesives capable of bonding metals were first invented: our Araldite® adhesive trade name is known and recognised worldwide in both the industry and in the home.

The question about what is one trying to accomplish when using an adhesive is not new. Man has used adhesives or glues since the dawn of history. The ancient Egyptians attached veneers to furniture with glue. These early glues were all natural substances. Nowadays synthetic resins and polymers are being used.

When components are bonded together, the adhesive first thoroughly wets the surfaces to be bonded together filling the gap in between and then starts to polymerize. When hardening is complete, the bond can withstand the stresses of use. High performance adhesives harden through chemical reaction and have a strong affinity to joint surfaces. Adhesive bonding is sometimes called chemical joining to differentiate it from mechanical joining.

Huntsman industrial adhesives

Adhesives have been used very successfully for years in many very demanding industries, like aerospace, automotive, wind energy, sport and leisure, railways, construction or medical.

Our industrial adhesives form extremely strong and durable bonds with plastics, metals, glass, rubber and many other materials. Designers in just about every industry increasingly find that bonding with Huntsman adhesives provides the answer to production problems created by new materials, new uses of existing materials, and new techniques and manufacturing methods.

Our industrial adhesives are easy to use, but to ensure successful bonding the directions given in the instructions supplied with the adhesive must be strictly followed.

In particular:

1. Resin and hardener components must be measured in the correct ratio as mentioned in our technical datasheets and thoroughly mixed together.
2. Joint surfaces must be degreased and, when necessary, pretreated.
3. Minimum curing temperature and curing time must be observed (data given in the technical datasheets).
4. Jigs or other fixtures must be used to prevent the bond surfaces from moving relative to one another during the curing process.
5. Though only light pressure is needed, it should be applied as evenly as possible over the whole bond area. Excessive pressure leaves the joint starved of adhesive.

Designing to bond

In order to get the best performance from an adhesive bond, it is important to design the component for bonding rather than simply taking a design made for mechanical fastening.

Methods of application of the adhesive and the assembly of the components, must always be considered at the design stage. Together, with the practical curing conditions, these determine the choice of adhesive type to be used.

A quality bond can only be produced when quality is considered at all stages of the design and production process.

Adhesives technology

1-2 Assessment of bonding

Advantages of adhesive bonding

> **Continuous bond**

The stress is uniformly distributed over the entire bond area when a load is applied whereas the stress is highly concentrated in a few areas when spot welding or mechanical fasteners are used. Bonded assemblies will therefore typically provide a longer service life under load.

> **Stiffer structures** (Figure 1)

The continuity of a bonded assembly will produce stiffer structures. Alternatively, if increased stiffness is not needed, the weight of the structure can be decreased while maintaining the required stiffness.

> **Improved appearance**

Adhesive bonding gives a smooth appearance to designs. There are no protruding fasteners such as screws or rivets, and no spot welds marks.

> **Joining sensitive materials**

Adhesive bonding does not require high temperatures. It is highly suitable for joining together heat sensitive materials prone to distortion or to a change in properties resulting from the heat of brazing or welding processes.

> **Complex assemblies**

Complex assemblies can often not be joined together by any other fastening technique. Composite sandwich structures being a typical example.

> **Dissimilar materials**

Adhesives can join different materials together – materials that may differ in composition, moduli, coefficients of thermal expansion, or thickness.

> **Reduced corrosion**

The continuous adhesive bond forms a seal. The joint is consequently leak proof and less prone to corrosion.

> Reduced stress concentrations (Figure 2)

A bonded structure is inherently a safer structure because the fewer and less severe concentrations of stresses are less likely to induce fatigue cracks. Fatigue cracks will propagate more slowly in a bonded structure than in a riveted structure – or even in a machined profile because the bond lines will typically stop crack formation.

> Electrically insulating

The adhesive bond can provide an electrically insulating barrier between the surfaces.

> Electrically conducting

Some adhesives are specifically formulated to offer high electrical conductivity (specially for electronic applications).

> Vibration dampening

Adhesive bonds have good dampening properties which may be useful for reducing sound or vibration.

> Simplicity

Adhesive bonding can simplify assembly procedures by replacing several mechanical fasteners with a single bond, or by allowing several components to be joined in one operation.

Adhesive bonding may be used in combination with spot welding or mechanical fastening techniques in order to improve the performance of the complete structure. All these advantages may ultimately translate into improved economic advantages: simplified design, easier assembly, lighter weight (reduced energy utilisation), extended service life.

Adhesives technology

1-2 Assessment of bonding

Fig.1 Stiffening effect - Bonding and riveting compared

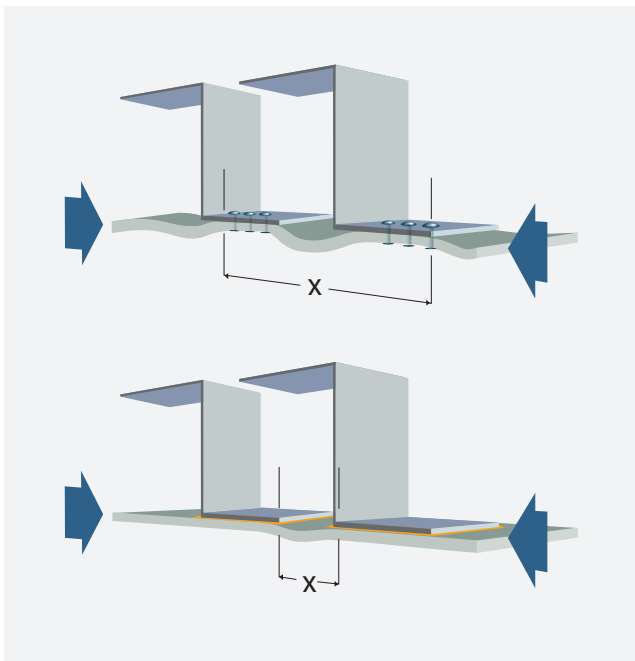

x = unstiffened area

The diagram shows how a joint may be designed to take advantage of the stiffening effect of bonding. Adhesives form a continuous bond between the joint surfaces. Rivets and spot welds pin the surfaces together only at specific points. Bonded structures are consequently much stiffer and loading may be increased (by up to 30 - 100%) before buckling occurs.

Fig.2 Stress distribution in loaded joints

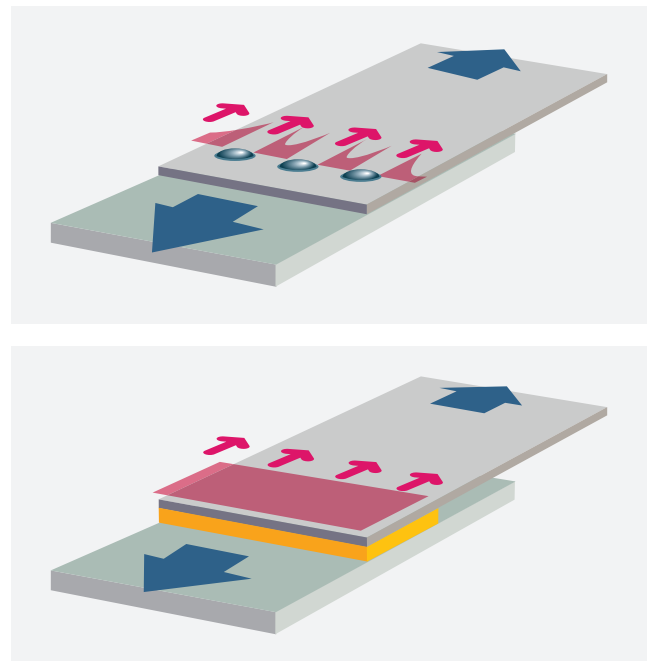

The riveted joint at the top is highly stressed in the vicinity of the rivets. Failure tends to initiate in these areas of peak stress. A similar distribution of stress occurs with spot welds and bolts. The bonded joint at the bottom is uniformly stressed. Likewise, stress will be uniformly distributed in a welded joint, however changes in the metal structure and strength will have taken place in the vicinity of the weld.

Limitations

> Temperature resistance

Adhesives are drawn from the class of materials known as 'polymers', 'plastics' or 'synthetic resins' and therefore have their inherent limitations. They are not as strong as metals however the difference is offset by the increased surface contact area provided by the bonded joints. With increasing temperature the bond strength decreases and the strain properties of the adhesive move from elastic to plastic. This transition is usually in the temperature range 70 – 220°C: the transition temperature depends on the particular adhesive.

> Chemical resistance

The resistance of bonded joints to the in-service environment is dependent on the properties of the polymer from which the adhesive is made. Possible exposure of the bonded structure to oxidizing agents, solvents, etc., must be kept in mind when selecting the adhesive type to use.

> Curing time

With most adhesives maximum bond strength is not produced instantly as it is with mechanical fastening or with welding. The bonded assembly must be supported while the bond strength is developing.

> Surface preparation

The quality of the bond may be adversely affected if the surfaces are not readily wetted by the adhesive during the bonding process (see part 2 of this guide).

> Process controls

Ensuring consistently good results may necessitate the setting up of unfamiliar process controls. A poorly executed bonding is often impossible to correct.

> In service repair

Bonded assemblies are usually not easily dismantled for repair.

Adhesives technology

1-2 Assessment of bonding

Adhesive types and main characteristics

Adhesives are classified either by the way they are used or by their chemical type.

High performance adhesives harden via a chemical reaction whereas lower performance types typically harden via a simple physical change.

The main types of adhesives typically used in industry today include:

> **Anaerobics**

Anaerobic adhesives harden when in contact with metal and air is excluded, e.g. when a screw is tightened in a thread. Often referred to as 'locking compounds' or 'thread sealants', they are used to secure, seal and retain machined, threaded, or similarly close-fitting parts. They are based on synthetic resins known as acrylics. Due to the curing process, anaerobic adhesives do not have gap-filling capability but offer the advantage of relatively rapid curing.

> **Cyanoacrylates**

A special type of acrylic, cyanoacrylate adhesives cure through reaction with moisture held on the surfaces to be bonded. They need close fitting joints. Usually they solidify in seconds and are suited to small plastic parts and to rubber. Cyanoacrylate adhesives have relatively little gap filling capability but can be obtained in liquid and thixotropic (non-flowing) versions.

> **Toughened acrylics / methacrylates**

These adhesives based on a modified type of acrylic, are fast curing and offer high strength and toughness. Supplied as two parts (resin and catalyst), they are usually mixed immediately before application. Some more specialised types are also available where the components can be applied in separate operations: the resin component to one surface to be bonded, the catalyst to the other. They tolerate minimal surface preparation and bond well to a wide range of materials. The products are available in a wide range of cure speeds and as liquids or pastes.

> UV curable adhesives

Specially modified acrylic and epoxy adhesives, which can be cured very rapidly by exposure to UV radiation. Acrylic UV adhesives cure extremely rapidly on exposure to UV, but require one substrate to be UV transparent. The UV initiated epoxy adhesives can be irradiated before closing the bond line, and cure in a few hours at ambient temperature or may be cured at elevated temperatures.

> Epoxies

Epoxy adhesives consist of an epoxy resin and a hardener. With many resins and different hardeners to choose from, they allow great versatility in formulation. They also form extremely strong durable bonds with most materials. Epoxy adhesives are available in one-component or two-component form and can be supplied as flowable liquids, as highly thixotropic products with gap filling capability of up to 25 mm, as films or even in powder form.

> Polyurethanes

Polyurethane adhesives are typically one-component moisture curing or two-component systems. They provide strong resilient joints, which are resistant to impacts. They are useful for bonding FRP (fibre-reinforced plastics) and certain thermoplastic materials and can be made with a range of curing speeds and supplied as liquids or as pastes with gap filling capability of up to 25 mm.

> Modified phenolics

First adhesives for metals, modified phenolics now have a long history of successful use for the production of high strength metal to metal and metal to wood assemblies, and for bonding metal to brake lining materials. Modified phenolic adhesives require heat and high pressure for the curing process.

The above types cure through chemical reactions. The following adhesive types are less performing, but still widely used in industrial applications:

> Hot melts

Related to sealing wax, which is one of the oldest forms of adhesive, today's industrial hot melts are based on modern polymers. Hot melts are used for the fast assembly of structures designed to be subjected to only light loads.

> Plastisols

Plastisol adhesives are modified PVC dispersions which require heat to harden. The resultant joints are often resilient and tough.

> Rubber adhesives

Based on solutions of latexes, rubber adhesives harden through solvent or water evaporation. They are not suitable for sustained loading.

> Polyvinyl acetates (PVAs)

Vinyl acetate is the principal constituent of the PVA emulsion adhesives. They are suitable for the bonding of porous materials, such as paper or wood, and general packaging applications.

> Pressure sensitive adhesives

Typically used with tapes and labels, pressure sensitive adhesives are designed to remain tacky and do not harden but are often able to withstand adverse environments. They are not suitable for sustained loading.

No one company supplies all these types of adhesives. Each supplier specialises in particular types.

Huntsman Advanced Materials supplies many industries with epoxy, polyurethane, modified phenolic, toughened methacrylate and UV curable acrylic adhesives under the trade names Araldite®, Epibond®, Epocast®, Agomet®, Euremelt®, Arathane® and Uralane®.

Adhesives technology

1-3 Designing a bonded joint

Loading conditions

It is critical that an assembly which will ultimately be bonded is designed with bonding in mind, rather than simply bonding a design intended for welding or mechanical fastening.

When designing bonded joints the following aspects must be considered:

- > Joint geometry
- > Adhesive selection
- > Adhesive performance properties
- > Service conditions
- > Stress in the joint
- > Manufacturing process

Bonded assemblies may be subjected to tensile, compressive, shear or peel stresses, or a combination thereof (Figure 3). Adhesives are more resilient under shear, compression and tension stresses. They perform less effectively under peel and cleavage loading. A bonded joint needs to be designed so that the loading stresses will be directed along the lines of the adhesive's greatest strengths.

To indicate the typical performance properties to be expected from a structural adhesive, the Huntsman Advanced Materials technical data sheet for the particular adhesive will usually report shear strengths and peel strengths obtained using standard test methods.

For example, the standard test method for shear (ISO 4587) uses a simple lap joint made from metal sheet, usually an aluminum alloy, 25 mm wide with 12.5 mm overlap. The mean breaking stress at room temperature will be in the range 5 to 45 N/mm² depending on the adhesive. At the top end of this breaking stress range, assemblies made from aluminum alloy sheet of up to 1.5 mm thickness will often cause the substrate to yield or break. (The lap joint is only one of several different types of bonded assemblies).

The breaking load of a lap joint is proportional to its width, but not to its overlap length. Although the breaking load will increase as overlap length is increased, the mean breaking stress will be reduced.

A method of determining the best dimensions for a simple lap joint is described in next chapter ([Determination of simple lap joints dimensions, p.20](#)). The strength of a joint is a complex function of the stress concentrations set up by the load. In a simple lap joint made from thin metal sheet there are two sorts of stress: shear and peel. Both the shear and peel stresses vary along the length of the joint, with concentrations at the ends. Alternative joint designs are shown thereafter where these stresses are more evenly distributed (Figure 4). The efficiency gained results in joints of greater strength.

Fig.3 Loading conditions

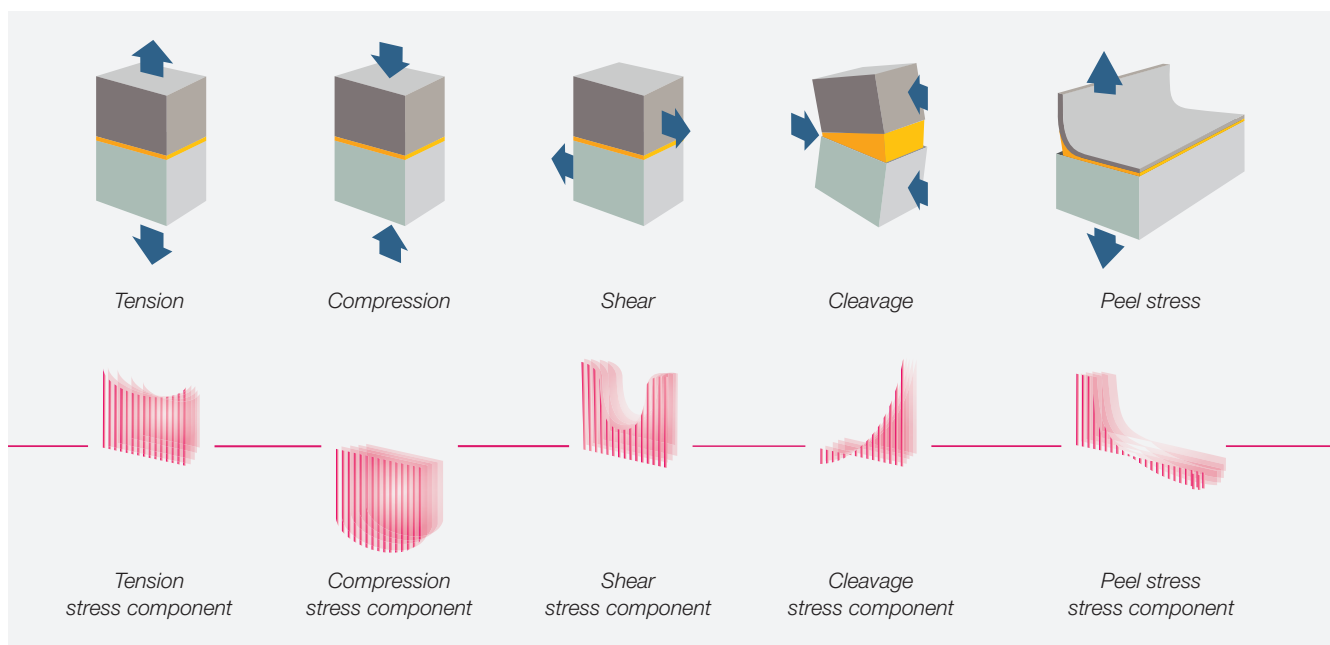

A bonded joint can be loaded in five basic ways (as shown in the diagrams above). Cleavage and peel loading are the most severe as they concentrate the applied force into a single line of high stress. In practice, a bonded structure has to sustain a combination of forces. For optimum strength, the bonded assembly should be designed in such a way as to avoid cleavage and peel stresses.

Adhesives technology

1-3 Designing a bonded joint

Fig.4 Basic bonded joints between strip / sheet metals

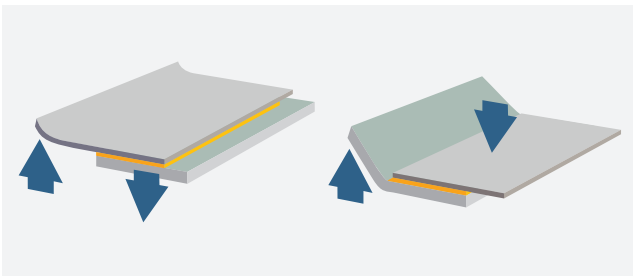

A peel joint can be designed such that the forces acting on it become compression forces, making a much stronger joint.

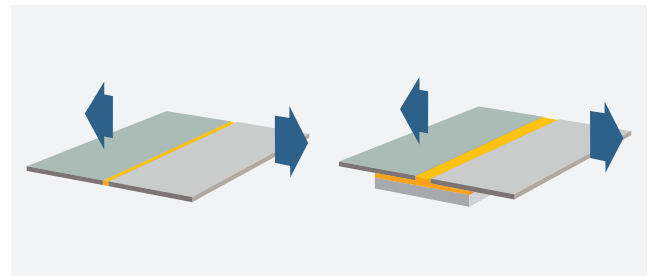

By adding a reinforcing plate to this butt joint, the forces run along a much stronger shear joint.

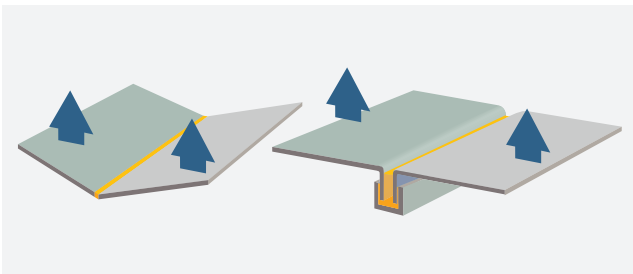

Weak cleavage joints can be strengthened through design, in this instance by adding a U-section to the previously bent sheet.

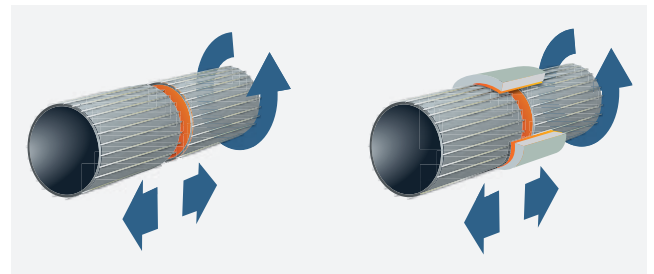

A similar effect is produced by sleeving this cylindrical butt joint.

The basic types of bonded joints are shown in the diagrams above. In practice, a combination of two or more basic types may be used – and the relative dimensions (and areas of bonded surface) of the joints may vary from those shown in the diagrams. Tapering of the ends of lap joints or scarf joints serves to distribute the stress more uniformly and reduce stress concentration.

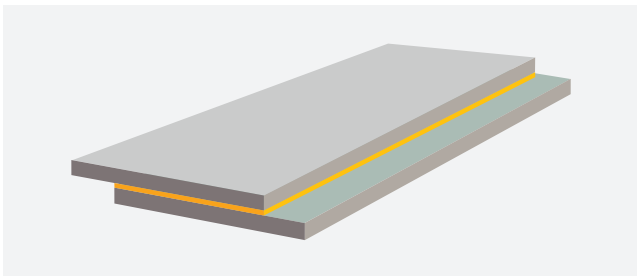

Simple lap joint - good.

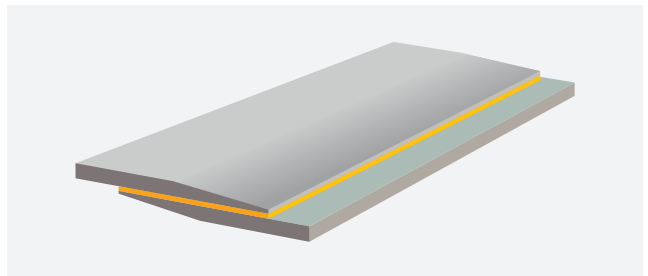

Tapered lap joint - very good.

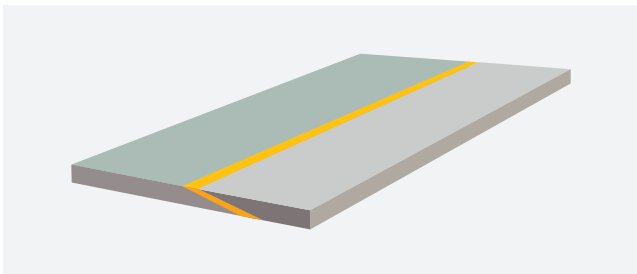

Scarf joint - excellent.

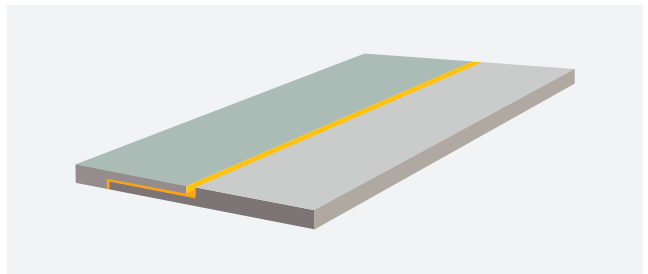

Stepped lap joint - very good.

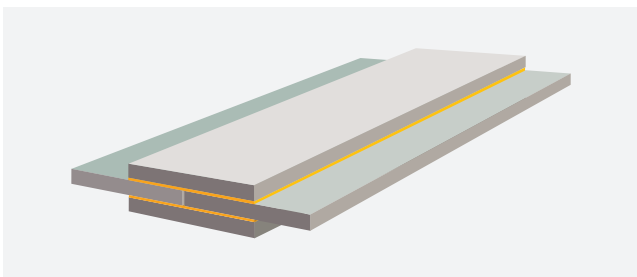

Double strap joint / double lap joint - very good.

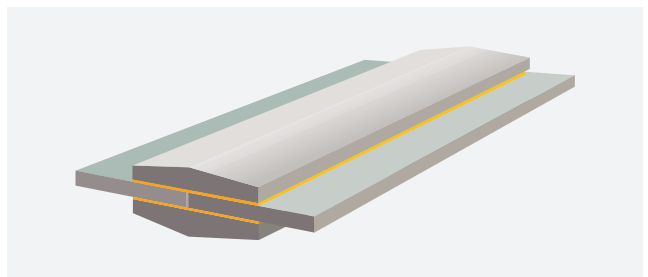

Tapered double strap joint - excellent.

Adhesives technology

1-3 Designing a bonded joint

Fig.5 Practical bonded joints between sheet materials

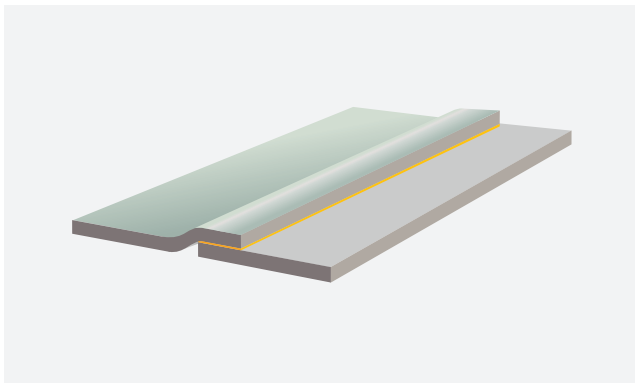

A

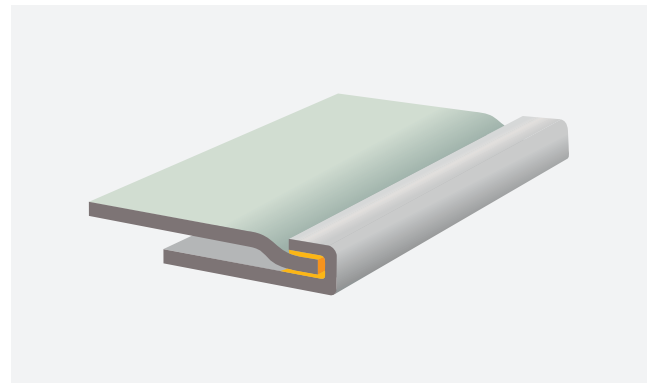

B

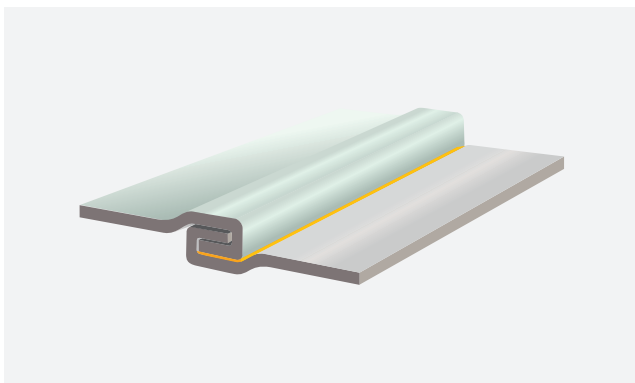

C

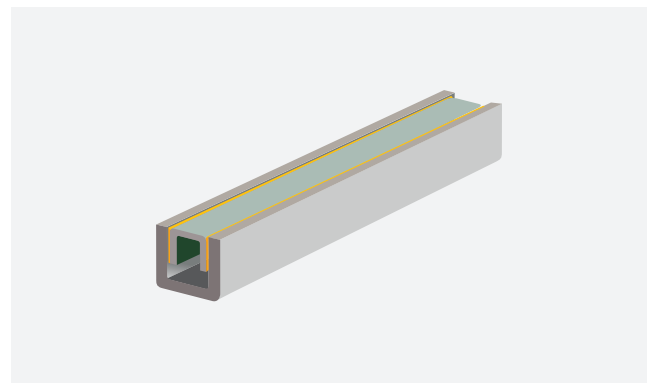

D

Certain metals, especially mild steel, are easily bent or folded to form advantageous joints. (A) shows a development from the simple lap joint, (B) a toggled joint and (C) shows further developments. Closed box structures (D) from formed sheet metal are easily produced using this folding and bonding technique to join the edges.

Fig.6 Bonding of multi-layer structures

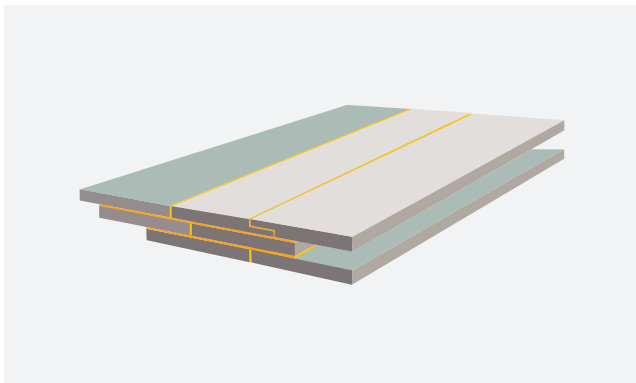

A

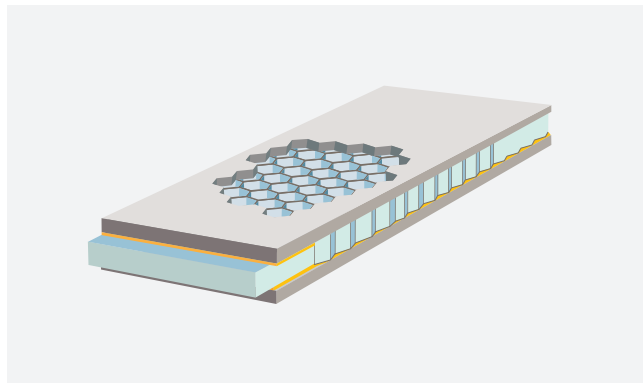

B

Multi-layer structures may be built up by adhesive bonding and may also be bonded to other parts. In (A) a multi-layer fibre-reinforced plastics laminate is joined to its neighbour by a multi-stepped lap joint. In (B) an edge member is bonded into a sandwich panel. On loading, the stresses will be transferred into the panel. The honeycomb core is itself assembled and bonded to the facing sheets with adhesives.

Adhesives technology

1-3 Designing a bonded joint

Fig.7 Joints using profiles

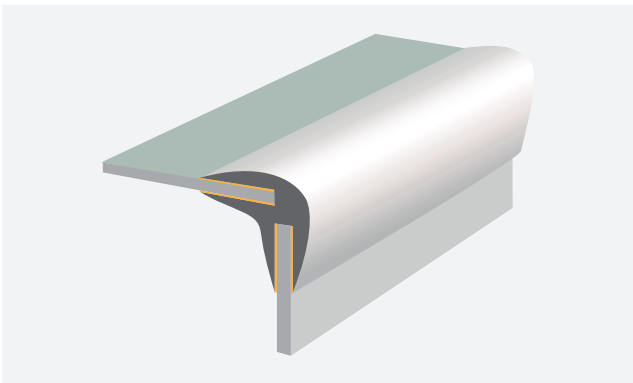

Sheets or plates that cannot be bent and folded may be bonded together by means of purpose-made profiles. Tapering removes the high stress concentrations caused by abrupt change in section.

Fig.8 Stiffening of large thin sheets

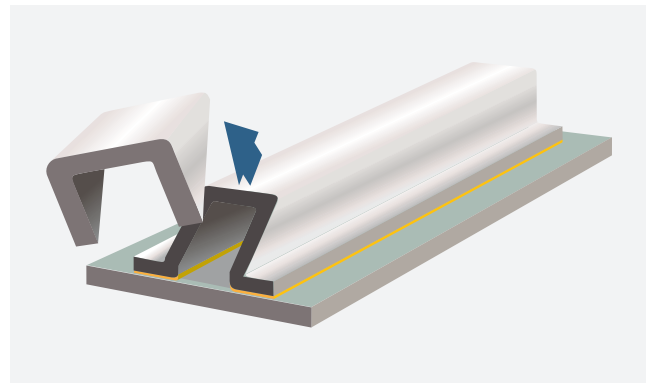

Large sheets of thin gauge material (metal or plastics) may be stabilised by bonding stiffeners made of the same material in similar gauge. The diagram shows a 'top hat' stiffener. Towards the edge of the sheet, the stiffener may be cut away (as shown) in order to reduce stress concentrations. The effect is similar to that of the scarf joint (Figure 4).

Fig.9 Bonded frameworks

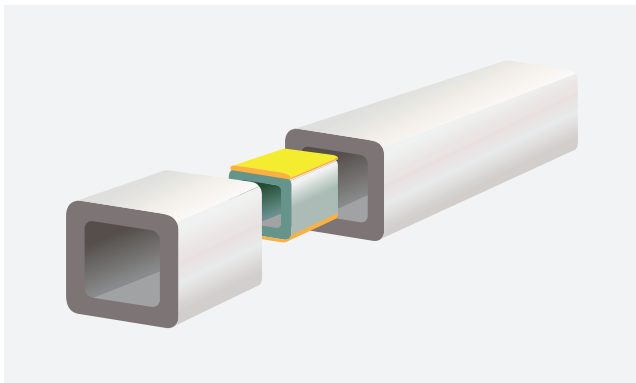

A. Plug design

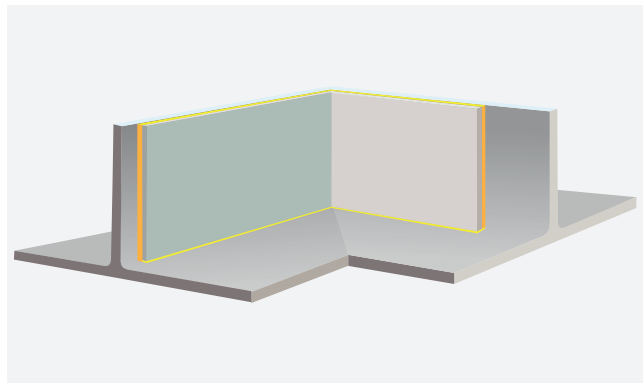

B. Angle design

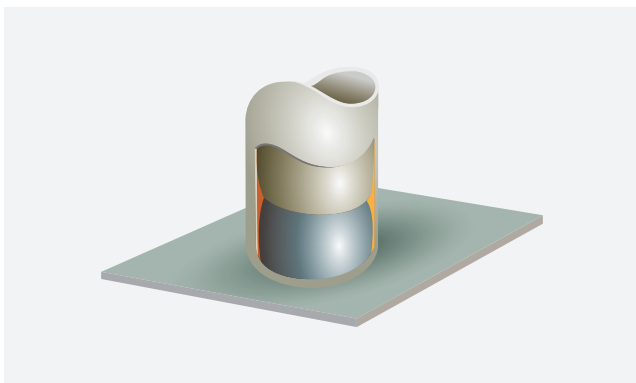

C. Boss design

Framework structures of square or round tubes, or simple profiles, may utilise plugs (A), angles (B), or bosses (C) at the joints. Use of these additional pieces greatly increases the area of bond surface at the joint.

Adhesives technology

1-3 Designing a bonded joint

Determination of simple lap joints dimensions

The shear strength of simple lap joint (Figure 10) depends on the nature of the metal, the adhesive, the thickness of the metal and the area of overlap.

Given the loading required and the metal and adhesive to be used, it is possible to predict:

1. Optimum overlap on metals of given thickness.
2. Optimum metal thickness for given overlap.

This overlap and thickness may be rapidly determined from a diagram based on results from one test program.

The test - to determine mean shear strengths of joints of various overlaps (**l**) and metal thickness (**t**) - must be sufficient to plot a curve of shear strength against **t/l**. A curve established in this way is shown thereafter (Figure 11).

Any particular point on an established curve represents (for lap joints made with metal and adhesive to the same specifications as used in the test program) the state of stress in a particular joint and shows the relationship between the dimensions of the joint (horizontal axis), the mean shear stress in the adhesive (vertical axis) and the mean tensile stress in the metal (slope of a straight line from the origin to the point).

Optimum overlap (**l**) is determined by using the diagram together with the formula: $\tau = \sigma \cdot t/l$

This formula is derived from the known design requirements:

P = load per unit width of joint

t = sheet thickness (t= thickness of thinner sheet in joints made of sheets of different thickness)

These establish:

σ = mean tensile stress in the metal = **P/t** and by definition:

τ = mean shear stress in the joint = **P/l**

Substituting for **P** gives: $\tau = \sigma \cdot t/l$ (Figure 12).

Optimum overlap (**l**) is determined as follows:

1. Calculate σ from **P** and **t**.
2. Starting from 0, mark on the diagram the straight line whose slope ($\tau / t/l$) is given by σ .
3. Where the straight line cuts the curve, read off the value for τ
4. Having determined σ and τ , and knowing **t**, substitute these values in: $\tau = \sigma \cdot t/l$ and calculate optimum overlap **l**.

Deviation from the optimum overlap reduces the efficiency of the joint. A too small overlap causes the joint to fail below the required loading, whereas a too large overlap may mean an unnecessarily large joint.

Optimum sheet thickness (**t**) is determined as follows:

1. Calculate τ from **P** and **l**.
2. Where the value of **t** cuts the curve, read off the value for **t/l**
3. Having determined **t/l** and knowing **l**, calculate optimum thickness **t**.

Fig.10 Simple lap shear joint

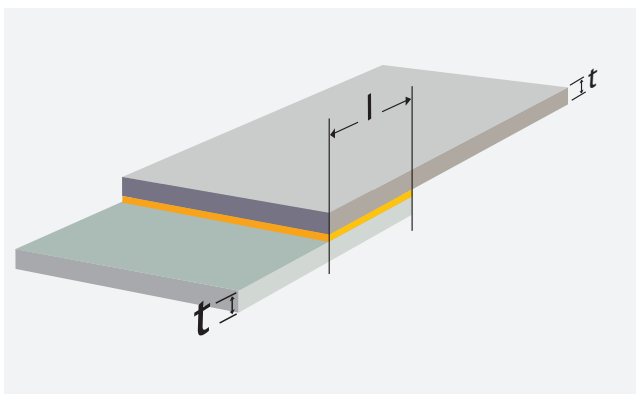

l = overlap | t = metal thickness

Fig.11 Correlation diagram between shear strength and t/l of simple lap joints

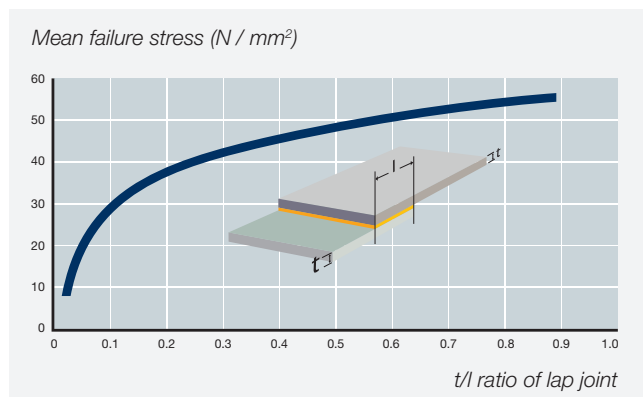

The diagram relates the dimensions of the joint, the shear stress in the adhesive and the tensile stress in the metal. The curve shown was established from a test program carried out on simple lap joints of BS 1470-HS30 aluminum alloy bonded with hot-cured Araldite® epoxy adhesive.

Fig.12 Conventional designs for stresses in a lap joint

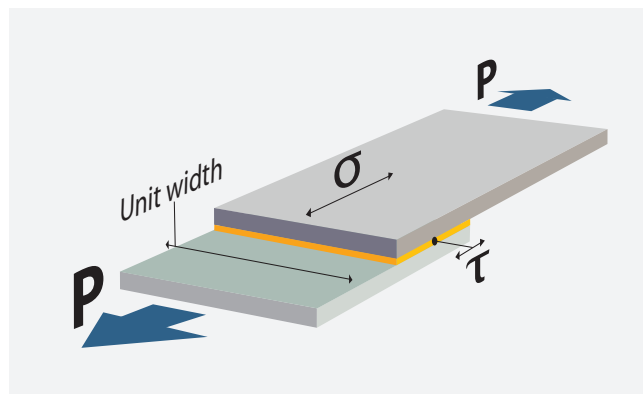

Adhesives technology

1-3 Designing a bonded joint

Durability of a bonded joint

The long-term performance of a bonded joint depends on the properties both of the adhesive and of the materials being joined. The adhesive will be affected by high temperatures, by powerful solvents or by water.

The durability of the joint will also depend on the effects of these agents on the materials being joined. Above all, it will depend on the condition of the joint surfaces when the bond was made.

The best joints are made when the surfaces are absolutely clean and have good affinity to the adhesive.

This necessitates control of pretreatment of the surfaces (part 2 of this guide). A poor surface condition usually results in a relatively low initial strength and a reduced durability. A thick bond line gives lower initial strength (Figure 13). With most types of adhesive, the application of heat to complete the curing process improves both initial strength and durability.

The user will have to assess the level of control of these factors necessary to produce a bonded joint satisfactory for the expected service conditions. For many applications a good and sufficient durability is obtained with easily achievable levels of surface control (or pretreatment), bond line thickness and curing schedule.

Shear strength decreases if the layer of adhesive is thick. The effect of increasing bond line thickness in simple lap joints made with hot cured epoxy adhesives is shown in the diagram (Figure 13).

The optimum bond line thickness is in the range 0.1 to 0.3 mm. In very thin bond lines there is risk of incomplete filling of the joint due to contact between high points on the joint surfaces.

The bonded joints may need to resist sustained loads, which are either static or vibrational. Joint designs in which peel stresses are at a minimum give the best durability. The fatigue testing (by standard methods) of simple lap shear joints made with epoxy adhesives will often give failure values of ca 30% of the short term measured breaking load (Figure 14).

Fig.13 Bond line thickness vs. shear strength

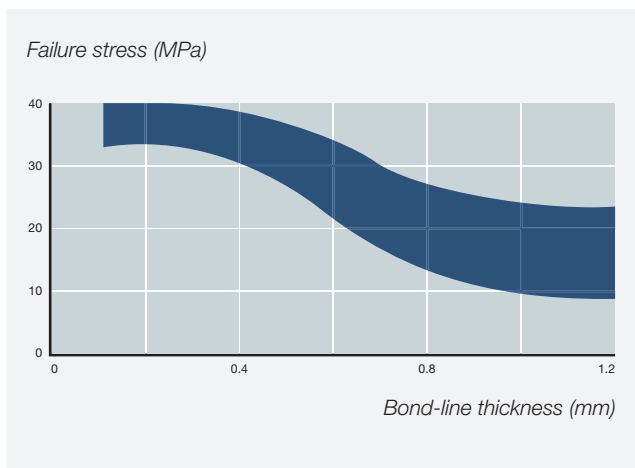

Adhesive strength at the interface is by its nature greater than the cohesive strength within the adhesive. The diagram shows that in this adhesive the drop in strength occurs in the range 0.4 to 1.0 mm. In thicknesses greater than 1.0 mm shear strength is approximately constant. The exact shape of the curve depends on the characteristics of the adhesive. Toughened adhesives will maintain higher values in thicker bond lines while more rigid adhesives will decline more quickly.

Fig.14 Fatigue strength (tensile) of lap joints

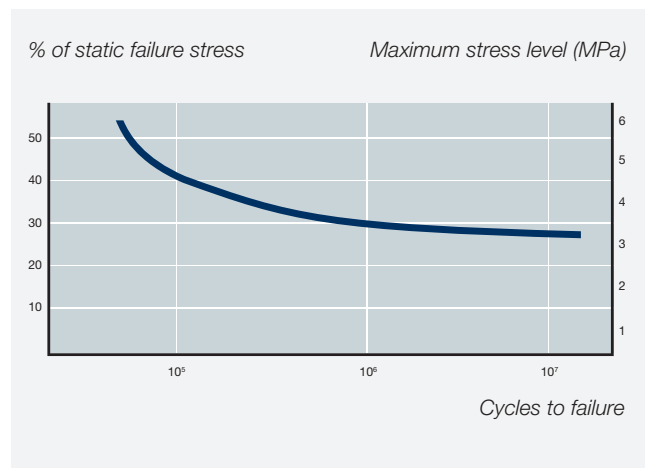

Fatigue strength of simple lap joints made with a cold cured epoxy adhesive and tested to DIN 53 285. In this test programme, the failure stress of control joints under static loading was 10 MPa. The diagram shows that under fatigue loading the joints required to sustain 10⁶ test cycles should not be stressed higher than 3.6 MPa per cycle.

Adhesives technology

1-3 Designing a bonded joint

Bonding process essentials

To make a successful bond, the adhesive must wet the surfaces to be assembled, fill the gap between the two surfaces, and then fully cure.

With a two-component adhesive this means that resin and hardener must be thoroughly mixed in the correct ratio. An appropriate amount of mixed adhesive needs to be placed and spread onto the bond area. Both steps can be performed with automatic equipment. The simplest equipment dispenses adhesive from pre-filled cartridges (Figure 15 and 16). An example of a typical mix-metering equipment, which meters, mixes and dispenses two-component adhesives is shown (Figure 17).

Where highly viscous or thixotropic components are used, the metering units may be fed by special drum pumps. Similarly for single component epoxy adhesives there are hand or air operated application equipment. Well designed and maintained application equipment will help ensure a reproducible and dependable quality bond. Suitable equipment is advantageous in setting up a Quality Assurance Scheme for a bonding process.

The continuous bonding process also requires a uniform and consistent surface preparation. All foreign contaminants must be removed from the surfaces. A particular surface treatment may be needed in order to improve the affinity for the adhesive. Surface preparation can be a multi-step process and typically includes mechanical abrasion and - to achieve optimum results - chemical etching (Part 2 of this guide).

In some instances known surface contaminants such as protective oils, may be absorbed by the adhesive in the bonding process – this ability is a characteristic of specially formulated oil-tolerant adhesives. In these cases the present contaminants define the surface condition.

The hardening or curing of reactive adhesives requires time. The time is shortened if heat can be applied. Furthermore, although strong bonds can be achieved after 2 to 24 hours at room temperature curing with many two-part adhesives, exposing the adhesive bond to higher curing temperatures – even a few degrees above room temperature – will usually increase the bond strength.

With some specific single component epoxy adhesives, curing temperatures as high as 180°C may be required in order to obtain the optimum properties. Elevated temperature curing may be carried out using:

> Hot air ovens

This is a practical method only when a large number of assemblies are in the oven at the same time or for continuous production lines. Heat transfer is relatively slow and affected by the assembly type and thickness. Infrared ovens can also be used.

> Heated presses

Steam or oil-heated platens can be used in flat bed presses with a rapid and controllable temperature rise. This method is ideal for production of large flat panels, e.g. for insulated container side panels.

> Induction curing

Magnetic field causes current to flow in a conductive substrate. The resistance to the current generates heat and cures the adhesive. This technique has been used where very fast heat up and cure is required.



Fig.15 Manual applicators dedicated to different cartridges sizes



Fig.16 Different types and sizes of easy to use packaging for Huntsman industrial adhesives



Fig.17 Mix-metering equipment for two-component adhesives (courtesy of DOPAG AG)

Huntsman Advanced Materials

Our Advanced Materials division is a leading global chemical solutions provider with a long heritage of pioneering technologically advanced epoxy, acrylic, phenolic and polyurethane-based polymer products.

Our capabilities in high-performance adhesives and composites, delivered by more than 1 600 associates, serve over 2 000 global customers with innovative, tailor-made solutions and more than 1 500 products which address global engineering challenges.

We operate synthesis, formulating and production facilities around the world



Distributed by

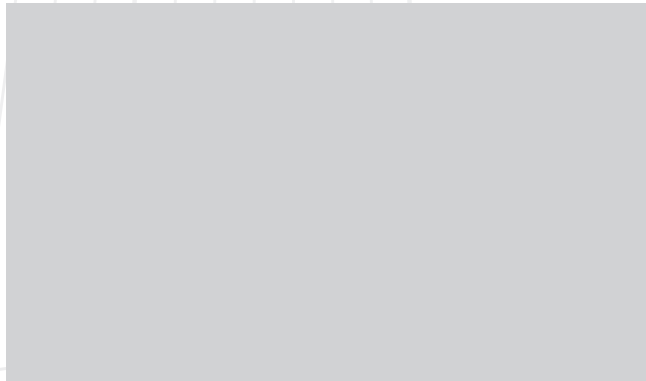

Find the right adhesive to fulfill your needs



www.AralditeAdhesives.com

HUNTSMAN

Enriching lives through innovation

For more information

www.huntsman.com/advanced_materials
advanced_materials@huntsman.com

Europe, Middle East & Africa

Huntsman Advanced Materials (Switzerland) GmbH
Klybeckstrasse 200
P.O. Box
4002 Basel
Switzerland
Tel. +41 61 299 1111
Fax +41 61 299 1112

Asia Pacific & India

Huntsman Advanced Materials (Guangdong) Co., Ltd.
Room 4903-4906, Maxdo Centre,
8 Xing Yi Road,
Shanghai 200336,
P.R.China
Tel. + 86 21 2325 7888
Fax + 86 21 2325 7808

Americas

Huntsman Advanced Materials Americas Inc.
10003 Woodloch Forest Drive
The Woodlands
Texas 77380
USA
Tel. +1 888 564 9318
Fax +1 281 719 4047

Legal information

All trademarks mentioned are either property of or licensed to Huntsman Corporation or an affiliate thereof in one or more, but not all, countries.

Sales of the product described herein ("Product") are subject to the general terms and conditions of sale of either Huntsman Advanced Materials LLC, or its appropriate affiliate including without limitation Huntsman Advanced Materials (Europe) BVBA, Huntsman Advanced Materials Americas Inc., or Huntsman Advanced Materials (Hong Kong) Ltd. or Huntsman Advanced Materials (Guangdong) Ltd. ("Huntsman"). The following supercedes Buyer's documents. While the information and recommendations included in this publication are, to the best of Huntsman's knowledge, accurate as of the date of publication, NOTHING CONTAINED HEREIN IS TO BE CONSTRUED AS A REPRESENTATION OR WARRANTY OF ANY KIND, EXPRESS OR IMPLIED, INCLUDING BUT NOT LIMITED TO ANY WARRANTY OF MERCHANTABILITY OR FITNESS FOR A PARTICULAR PURPOSE, NON-INFRINGEMENT OF ANY INTELLECTUAL PROPERTY RIGHTS, OR WARRANTIES AS TO QUALITY OR CORRESPONDENCE WITH PRIOR DESCRIPTION OR SAMPLE, AND THE BUYER ASSUMES ALL RISK AND LIABILITY WHATSOEVER RESULTING FROM THE USE OF SUCH PRODUCT, WHETHER USED SINGLY OR IN COMBINATION WITH OTHER SUBSTANCES. No statements or recommendations made herein are to be construed as a representation about the suitability of any Product for the particular application of Buyer or user or as an inducement to infringe any patent or other intellectual property right. Data and results are based on controlled conditions and/or lab work. Buyer is responsible to determine the applicability of such information and recommendations and the suitability of any Product for its own particular purpose, and to ensure that its intended use of the Product does not infringe any intellectual property rights.

The Product may be or become hazardous. Buyer should (i) obtain Material Safety Data Sheets and Technical Data Sheets from Huntsman containing detailed information on Product hazards and toxicity, together with proper shipping, handling and storage procedures for the Product, (ii) take all steps necessary to adequately inform, warn and familiarize its employees, agents, direct and indirect customers and contractors who may handle or be exposed to the Product of all hazards pertaining to and proper procedures for safe handling, use, storage, transportation and disposal of and exposure to the Product and (iii) comply with and ensure that its employees, agents, direct and indirect customers and contractors who may handle or be exposed to the Product comply with all safety information contained in the applicable Material Safety Data Sheets, Technical Data Sheets or other instructions provided by Huntsman and all applicable laws, regulations and standards relating to the handling, use, storage, distribution and disposal of and exposure to the Product. Please note that products may differ from country to country. If you have any queries, kindly contact your local Huntsman representative.

© 2017 Huntsman Corporation. All rights reserved.
Ref. No. User's guide adhesives 06.17_EN_EU



Registered for
REACH