

# COUNTERTOP FABRICATION

WE ARE THE ADHESIVE EXPERTS FOR ANY APPLICATION



WE SELL THE **COMPLETE PACKAGE** FOR YOUR GRANITE & SOLID SURFACE APPLICATIONS

- Abrasives
- Adhesives
- Cleaners
- Chip Repair Kits
- CounterBalance®
- Dispensing Guns
- Hot Melts
- Protection Film
- KEEP-NUT™ Anchoring Systems
- Rodding Adhesives
- Sealants
- Sealers
- Silicones
- Under Mount Sink Fasteners™



Order online at [www.chemical-concepts.com](http://www.chemical-concepts.com) or call **1.800.220.1966**



## Table of Contents

Why Us?.....	3
Seaming Adhesives.....	4
Structural Adhesives .....	5
Rodding Adhesives.....	6
Epoxies/Acrylics .....	7
Laminating and Honeycomb Epoxy .....	8
Cel Components Honeycomb Panels .....	9
Fast-Con® .....	10
KEEP-NUT™ Sink Anchor Inserts.....	11
KEEP-NUT™ Kits Parts and Kits .....	12
KEEP-NUT™ Drilling Machine.....	13
Sink Clips and Glue-On Sink Anchors .....	14
Glue-On Sink Anchor Kits.....	15-16
Undermount Sink Hardware.....	16
CounterBalance® Float Frame Brackets .....	17
CounterBalance® Flat Plate and Half-Wall Overhang Brackets.....	18
CounterBalance® Cabinetry Overhangs .....	19-20
CounterBalance® Floating Countertop Brackets .....	21-23
CounterBalance® Shelving Brackets .....	24
CounterBalance® Surface, Stair & Cleat Brackets.....	25
Sealers and Cleaners .....	26
BoaBond Advanced Hybrid Adhesive.....	27
Sealants .....	28
Silicone - 100% RTV .....	29
Chem-Set™ Chip Repair Kits .....	30-31
Porcelain Scratch Repair Kit .....	32
Tape and Surface Protection Film.....	33
Hot Melt Adhesives.....	34
Dispense Guns Industrial .....	35
Dispense Guns Hot Melt .....	36
Abrasives and Pads .....	37-39
Contact Cements .....	40
Polypropylene and Polyethylene Adhesives.....	41

# COUNTERTOP FABRICATION



## Why Us?



### About Us

Chemical Concepts provides engineered solutions involving adhesives, sealants, tapes, and specialty fasteners. We work with manufacturers, fabricators, engineers and business owners to solve design challenges, and improve outcomes both in terms of process improvement and product performance.



### FABRICATORS COME TO CHEMICAL CONCEPTS WHEN:

- Looking for the right adhesive for their application, and confidence that the solution provided will work
- Motivated to improve processes, decrease cycle times and cut labor costs
- Frustrated by poor color matches, bleeding, or wasted time spent color matching. Difficulty matching white quartz!
- Challenges working with porcelain, quartzite, glass, outdoor kitchens and other difficult materials and projects.
- Looking to reduce breakage, call backs, waste, and other excess costs from the shop
- Frustrated at the lack of knowledge and expertise at "generalist" distributors
- Looking for solutions for vertical applications, panel hanging & cladding
- Looking for a partner to consolidate adhesives, tapes and sealants and related products from one vendor
- Seeking superior customer service, support, logistics, product freshness, product assortment and product availability
- In search of the latest and greatest advancements in adhesive technology
- Confused by the multitude of adhesive technologies, brands, and offerings
- Tired of dealing with large corporate distributors that do not provide personal attention

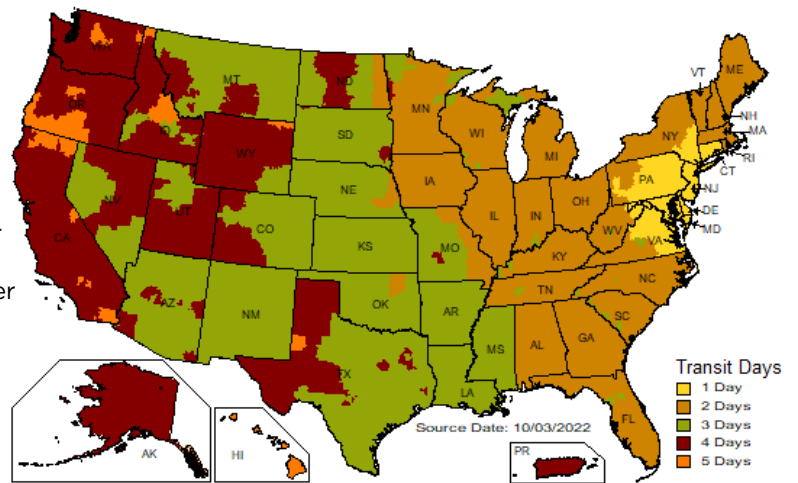

*Top Represented Manufacturers. Learn why our customers continue to stick with us!*

Rely on the Adhesive Experts with answers to your questions based on our 40+ years of experience servicing Fabrication Markets



# COUNTERTOP FABRICATION

## Seaming Adhesives

Better Color Matches vs Epoxy

CREATE A PERFECT SEAM EVERY TIME!



### Integra Adhesives

## SURFACE BONDER RAPID

**NEW**

Surface Bonder Rapid adhesive is developed especially to improve production output for high volume fabrication. The high strength, no sag formula is available in a range of colors to match the most popular surface designs.

- 2X faster set up time compared to the standard formula
- Sandable in 15-18 min @ 70°F
- Perfect seaming adhesive for colder climates/seasons
- Save time on installs and fabrication
- Designed for Natural Stone, Quartz, Compact Ceramics, and Porcelain surfaces



### SURFACE BONDER **Rapid** High Speed Seaming Adhesive

#### GUN



VR210XSP  
Dual Variable  
10:1 Gun

#### Mixing Tip

INTTIPSXSTREAM



## SURFACE BONDER ZERO

Surface Bonder Zero is a non sagging adhesive specifically designed for Quartz, Compact Sintered Materials and Natural Stone products. Its non-sag properties make it ideal for mitered edges, the adhesive stays right where you put it.

- Revolutionary seaming adhesive Designed for granite, marble, porcelain, sintered stone, glass, engineered stone, and natural stone products
- Drip-less 'Non-Sag' Acrylic Adhesive
- Designed for vertical applications, mitered edges and deck seams

250 ml



### SURFACE BONDER **ZERO** Zero Sag Seaming Adhesive

#### GUN



VR210XSP  
Dual Variable  
10:1 Gun

#### Mixing Tip

INTTIPSXSTREAM



## SURFACE BONDER XI

Surface Bonder XI is the latest generation of color matched adhesives for the surfacing industry. Developed for modern demanding fabrication methods such as laminating, mitering, v-grooving, integral mounted sinks and bowls, and applications subject to dynamic loads.

- Seaming Adhesive for Quartz Natural Stone, Solid Surface, Ceramic and more
- Eliminate Hand Mixing and Tinting
- Cures in as little as 20 minutes

250 ml



### SURFACE BONDER **XI**

#### GUN



VR210XSP  
Dual Variable  
10:1 Gun

#### Mixing Tip

INTTIPSXSTREAM



## SEAMING ADHESIVE COLOR MATCH TOOL **NEW TOOL!**

Finding the matching adhesive for your surface is easy! Search for the color name or manufacturer of your solid surface, quartz, porcelain or natural stone below and find the best match for your seams, joints and miters.

COLOR MATCH TO ALL STONE AND SOLID SURFACE COLORS

FEATURING:

IntegraAdhesives



Cross match to hundreds of manufacturers to find your color fast!

## Structural Adhesives

### Integra Adhesives



#### COMPONENT BONDER

Component Bonder is a dripless, quick drying, acrylic structural adhesive that bonds steel, aluminum, and fiberglass to all solid surfaces. Perfect for rodding and bonding clips.

- Two-part methacrylate, structural rodding, and clip bonding adhesive
- 400ml 1:1 adhesive cartridge that fit in standard 1:1 and 2:1 dispensers.
- Working time of 4 to 8 minutes
- Achieves nearly 90 percent of its ultimate strength in 10 to 15 minutes at room temperature curing

#### component BONDER

##### GUN



Integra  
400ML  
1:1 Gun

##### Mixing Tip

INTTIPSBLUE



#### RODDING BONDER

Rodding Bonder RD50 is an epoxy based Bonder packaged in a 500ml dual component cartridge designed to embed fiberglass or steel reinforcement rods in countertops. Testing shows that the process can improve load tolerance up to 300% and deflection up to 1600%.

- Rodding Natural Stone
- Much higher strength than Polyester
- Less waste and more accurate mixing versus bulk
- Effective rodding on wet/damp stone



#### RODDING BONDER

Stone Rodding Adhesive

##### GUN



VR210XSP  
Dual Variable  
10:1 Gun

##### Mixing Tip

INTTIPXSTREAM



#### SURFACE BONDER ULTRA

Surface Bonder Ultra is a premium, UV stable, Modified Hybrid Polyaspartic surfacing adhesive for indoor and outdoor applications. This unique adhesive will not yellow, stain, or bleed making it perfect for white marbles.

- Laminating / Seaming / V-Groove systems Automates Adhesive Application
- Provides the Strength of Epoxy, the Speed and Color stability of Acrylic
- Reduce Waste, Eliminate Hand Mixing and Tinting
- Polish to match the gloss of surrounding material



#### SURFACE BONDER ULTRA

The Ultra Versatile Adhesive

##### GUN



VR200XSP  
Dual Variable  
2:1 Gun

##### Mixing Tip

INTTIPSULTRA



#### SUBSTRATE BONDER

Substrate Bonder SB100 is a rapid cure, two-component polyurethane adhesive for attaching substrates in countertop applications.

- Attach Quartz, Natural Stone and Solid Surface to wood or composite support structures
- SB100 greatly reduces assembly time, curing in as little as 15 minutes
- High strength and flexibility (elongation >100%)



#### substrate BONDER

##### GUN



VR200XSP  
Dual Variable  
1:1 Gun

##### Mixing Tip

INTTIPSBLUE



## Rodding Adhesives Rodding That Actually Works

### Chem-Set™ **Rodmaster** Structural Acrylic Rodding Compound

- Apply while stone is damp
- Low-Shrinkage Rodding Material which lessens the chances of breaks on marbles and quartzites



### Chem-Set™ **6600X QUICK SET**

- Two part methacrylate which has a faster time
- No need to wait for the stone to dry: No more blow torching or long waiting times
- 5-10x the strength compared to polyesters
- Easy to use Cartridge. Improves stones load capacity

**SKU: CCA-6600X-400F**

	Work Time	Color
	3-6 min.	Hazy Clear
<b>Size</b>	400ml & 600ml	
<b>Guns</b>		
<b>Mixer</b>	MFQ-08-24T MIX RATIO: 1:1	
<b>Cure</b>	15 MINUTES	



### Chem-Set™ **6600T QUICK SET**

- Quick Working Time: Working time of 4 minutes and reaches handling strength in 10 minutes
- No need to wait for the stone to dry: No more blow torching or long waiting times
- 5-10x the strength compared to polyesters
- Easy to use Cartridge. Improves stones load capacity

**SKU: CCA-6600T-500**



	Work Time	Color
	3-6 min.	Hazy Clear
<b>Size</b>	500ml	
<b>Guns</b>		
<b>Mixer</b>	MFQX-08-24T MIX RATIO: 10:1	
<b>Cure</b>	15 MINUTES	



### Chem-Set™ **633LV EPOXY**

- Epoxy Based Adhesive for natural stone and quartz
- Cures within 15-20 minutes. Low Cost, Meter Mix
- Eliminate Hand Mixing
- Reduce Labor and Waste to Produces a low Cost system for reinforcing stone
- Adheres to steel and fiberglass reinforcing rods

**SKU: CCA633LV-600**

	Work Time	Color
	5-7 min.	Clear
<b>Size</b>	250ml	600ml
<b>Guns</b>		
<b>Mixer</b>	MGG-08-20T	160-AN824
<b>Cure</b>	15 MINUTES AT ROOM TEMPERATURE	

## Carbon Fiberglass Rodding

For use on granite, marble and engineered stones to add strength and reduce cracking. Made of the highest concentration of fiberglass strands.

- No Rust
- Bonds to Adhesives

**Roll size:**  
1/8" Thickness  
x 3/8" Width x 328' Length

**SKU: WHA-133229**



## Economy Fiberglass Rodding

This Economy Rodding could have applications in more dense granite materials and tight pattern granite materials.

- No Rust
- Bonds to Adhesives

**Roll size:**  
1/8" Thickness  
x 3/8" Width x 300' Length

**SKU: WHA-8160066**

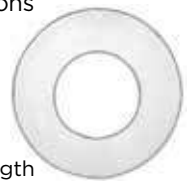

## Epoxies/Acrylics

# Chem-Set™ Fast Curing Adhesives

FOR NATURAL STONE

Work Time	Color
5-10 min	Clear/Amber
25ml	
50ml	
400ml	
FULL CURE IN 24 HOURS	

### Chem-Set™ 633 Quick Set Epoxy

SKU: CCA633

Quick set Epoxy used for porous substrates like granite, marble, concrete, wood and stainless steel surfaces. Fast Cure for undermount sink anchors.

- Thixotropic, non migrating adhesive for filling gaps
- Non sag for Vertical surfaces
- High tensile strength

OPAQUE



25ml

50ml



400ml

FOR SOLID SURFACE AND ENGINEERED STONE

Work Time	Color
3-6 min.	White/Clear
25ml	
50ml	
400ml	
FUNCTIONAL CURE	

### Chem-Set™ 605 Quick Set Acrylic

SKU: CCA605

Acrylic adhesive for use on Solid Surface, Engineered Stone, Plastics and Metals.

WHITE/CLEAR



25ml



50ml



400ml

## Chem-Set™ 650 UC ULTRA CLEAR Quick Set Epoxy

SKU: CCA650UC

Medium viscosity, liquid epoxy system for bonding natural stone. It is excellent for seams, lamination, repairs and applications that require a UV-stable, optically-clear appearance that is suitable for interior and exterior use. This epoxy is quick setting and fast curing, with ample working and positioning times.

Work Time	Color
4 minutes	Clear
50ml Cartridge	
16 oz Kit	
Gallon	
NON YELLOWING	
FOR INTERIOR AND EXTERIOR USES	

### 50ml Cartridge

- Includes TAH190-620 Mixing Tip
- In easy 1:1 mix ratio



50ml

### 16 oz Kit

8 oz. each



### 650 UC Part A&B Gallons



All these products are available in bulk packaging (1 gallon and buckets)



## Laminating and Honeycomb Epoxy

### ARALDITE® 9102 Fire-Rated Honeycomb and Laminating Epoxy

Epoxy system for laminating natural and engineered stone to composites for production of lightweight stone panels. Great for commercial panels, elevators, air, rail, and bus panels.



Achieve high performance, thermal cycling resistance, and aging resistance with **ARALDITE® 9102** adhesive. Specially designed for higher-end panel bonding applications. Perfect for creating rigid structures when using composites and metal substrates.

#### Product benefits

- Short curing time in RT
- Ease of application
- Good mechanical properties
- Excellent thermal cycling resistance
- Excellent damp-heat resistance
- Preferred cohesive failure mode
- Strong rolling peel strength



### Chem-Set™ Compbond 638 Water-Clear Epoxy



Available in **3 Gallon Kit** (2 Gallon Part A, 1 Gallon Part B),  
**15 Gallon Kit** (10 Gallon Part A, 5 Gallon Part B)

**Compbond 638** is water-clear, polishable and, unlike polyester and acrylic adhesives, it will not shrink. With **Compbond 638 Clear**, you'll never have to return to a job site to solve adhesive problems. It lays down a thin, tight bond line, and Bullnoses stay put. In addition it grabs, holds and sets, despite humidity or freeze/thaw conditions. You can shorten set time by applying heat. Tinting is also easy, because **Compbond 638** is a clear epoxy.

#### Applications

- Honeycomb Adhesive for Lamination to Stone
- Countertop Fabrication
- Stone lamination
- Laminating stone to other construction materials
- Excellent for rodding countertops
- Stone patching, mending, repairing, and bonding

SKU: CCA638A/B-03GK

### Chem-Set™ Compbond 639



Available in **1 Gallon Kit** and **7 Gallon Kit** (5 Gallon Part A, 2 Gallon Part B)

**Compbond 639** is a high-strength epoxy honeycomb and sandwich panel bonding adhesive that forms a thick epoxy bed, which allows you to adjust tile, stone, or countertops onto uneven surfaces. This super knife-grade epoxy is also smooth enough for troweling and is ideal for slab bonding- either spot bonding or full trowel. Exceeds ANSI-A-118.3 requirements.

#### Applications

- Adhering honeycomb
- Tiling walls, boat decks, elevators walls, steel-cased stairs
- Setting stone on an outdoor fireplace
- Adhering stone to stainless steel or aluminum
- Installing countertops
- Working with chemical-resistant areas and other difficult bonding jobs

SKU: CCA639A/B-7GK

## CEL Components Honeycomb Panels



**CEL COMPONENTS**



CEL COMPONENTS produces honeycomb composite sandwich panels which can be used as light-weight backer boards for thin porcelain or natural stone. These panels are available in a variety of configurations, with aluminum or fiberglass skins and even translucent panels for backlit applications.

### Realize the power of lightness in your fabrication:

- Easier installation and handling
- Improved durability & stiffness
- Reduced breakage and rework
- Reduced material and labor costs

These characteristics make our products ideal for thin porcelain fabrication, marine applications, elevator panels, facades and exterior cladding, furniture, RV & rail, ceiling panels, and high end commercial interiors.

Chemical Concepts provides a complete system including panels, specially formulated, high performance epoxy resin, and mounting solutions.



### ALUSTEP<sup>®</sup> 500

Aluminum honeycomb with fiberglass skins.



### COMPOCEL<sup>®</sup> ALP

Aluminum honeycomb with aluminum skins.



### CLEARSTEP

Translucent composite panel for backlighting.

Cel panels are available in a variety of thicknesses, sizes, materials to fit your requirements.

# COUNTERTOP FABRICATION

## Fast-Con® Removable Panel Anchor

**NEW**

**Specialinsert®**  
OUR TRADITION IS TO INNOVATE

# FAST-CON®

QUICK PRESSURE FASTENING SYSTEM IN STAINLESS STEEL

The **FAST-CON** is the revolutionary, patented, stainless steel fastening system that allows you to quickly connect panels and other components together in a snap! The **FAST-CON** clip system allows for a concealed mechanical fixing, making the union of two parts quick and reliable.



### Installation is simple with 4 easy steps!

<p>① Fasten the female <b>FAST-CON® FC-01-FE.5_</b> on the structure by screwing, bonding or riveting</p>	<p>② Insert the <b>FC-01-CE.50</b> centering device into the female clips</p>
<p>③ Position the panel and exert slight pressure to mark the location for the <b>FC-01-MA.5_</b> male part</p>	<p>④ Secure the male part <b>FC-01-MA.5_</b> at the markings</p>

### Starter Kit with Accessories

**SKU: SPE-FC-01-301-STRKIT2**

- 12 sets of (M & F) Fast-Con Fasteners
- 4 Center Marker tools
- 24 Screws
- 1 removal tool



### FEMALE Removable Fastener

- 316 Stainless Steel

**SKU: SPE-FC-01-FE.53**



### MALE Removable Fastener

- 316 Stainless Steel

**SKU: SPE-FC-01-MA.51**

- 303 Stainless Steel

**SKU: SPE-FC-01-MA.50**



### Removable Fastener Set

- (1) Female 316 Stainless Steel
- (1) Male 316 Stainless Steel

**SKU: SPE-FC-01-FE.51-MA.51-ST**



### Center Marker

- Stainless Steel

**SKU: SPE-FC-01-CE.50**



### Removal Tool

- Stainless Steel

**SKU: SPE-FC-00-LE.12**



### Self Tapping Screws

- 316 Stainless Steel
- 4.8mm D x 9.5mm L

**SKU: SPE-FC-VTB4.8X9.5.51**



See our complete line of products @ [chemical-concepts.com](http://chemical-concepts.com)

## KEEP-NUT™ Sink Anchor Inserts





### KEEP-NUT™ Sink Anchor Inserts for Under-Mount Sinks

KEEP-NUT™ Press-In self-anchoring sink fasteners are the strongest and most efficient mounting system for attaching undermount sinks to granite, quartz, solid surface, porcelain, and a variety of other hard surfaces. Originally designed to support building facades, vertical wall panels and furniture, the KEEP-NUT™ also offers exceptional performance for sink mounting.

- Quick Assembly by Pressure
- No Need for Resins or Adhesives
- Strongest Anchor on the Market
- Save Time & Money
- Can be drilled with standard tools (CNC, Grinder or by Hand)
- Average Strength of 562 lbs per Insert
- Crowns (or Teeth) Provide Axial Strength and Flex, Providing Higher Strength



**Works on:**

 GRANITE	 MARBLE	 ENGINEERED STONE	 UHPC
 PORCELAIN	 SOLID SURFACE	 GLASS	 COMPOSITES

#### Drilling Methods: CNC (All Surfaces)



#### Hand Drill (Solid Surface)



#### KEEP-NUT™ Drilling Machine (All Surfaces)

#### KDM115 KEEP-NUT™ Drilling Machine

Use 11.8 drill bits only

**CCH-KN-KDM115**  
(Vacuum Drilling  
Machine w/Polisher)



### Which Bit is Right for Me?

Type of Bit	Drilling Method	Surfaces
11.4mm 5/8-11 Thread Grinder Bit	KEEP-NUT™ Drilling Machine	Natural/Engineered Stone
11.8 mm 1/2 GAS CNC Bit (for CNC Routers)	CNC	Natural/Engineered Stone
11.8 mm Hand Drill / Drill Press Bit	Manual	Solid Surface/Plastics

### KEEP-NUT™ Insert & Pull-Out Strength

Part	Minimum Surface Depth(s)	Thread (d1)	Hole Depth (l2)	Hole Diameter (d2)	Threaded Post Depth (h1)	Number of Crowns	Average Pull-Out Strength
IM2S/P14-.20/H6	0.34" 8.5 mm	1/4-20	0.26" 6.5 mm	11.8 mm	0.22" 5.5 mm	2	562 lbf 2.5 kN

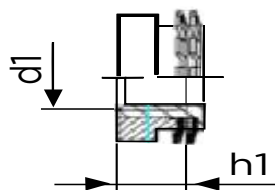

**2 Crown Type**

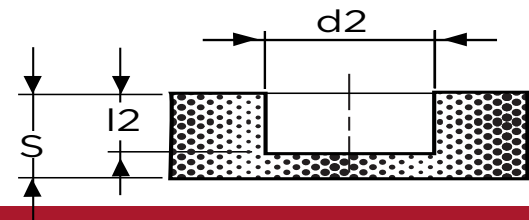

## KEEP-NUT™ Parts and Kits

By 

**Individual Items:** As a fabricator you may want to purchase all items from us or just the **KEEP-NUT™** Inserts by themselves, see part numbers and kits below:

<b>KEEP-NUT™</b> SKU: SPE-IM1S/P1.4-20/H5		<b>1 Crown KEEP-NUT™ Insert</b> Average Strength of <b>202 lbs</b> per Insert
<b>KEEP-NUT™</b> SKU: SPE-IM2S/P1.4-20/H6		<b>2 Crown KEEP-NUT™ Insert</b> Average Strength of <b>562 lbs</b> per Insert
<b>Z-Shaped Sink Clips</b> SKU: CCH732G		Z-Shaped Sink Clip used to support the undermount Sink
<b>Allen Posts</b> SKU: CCH-KNPOST		1/4-20 Thread x 1-1/4" Length Male Posts <i>Additional 1-1/2" L Post, 1/4-20 Thread sizes available 1-3/4" L Post, 1/4-20 Thread</i>
<b>Wingnuts</b> SKU: CCH730S		1/4-20 Thread Wingnut
<b>Lock-Nuts</b> SKU: CCH734K		1/4-20 Thread Lock Nut (Optional, replaces Wingnut & Star Washer)

### Drill Bits & Installation Accessories:

<b>11.8 mm CNC Stone/Quartz Bit</b> SKU: CCH-KNBITCNC-11.8MM		11.8 mm 1/2 GAS CNC Bit for Stone/Quartz
<b>11.4 mm Manual Stone/Quartz Bit</b> SKU: CCH-KNBITGRI-11.4MM		11.4 mm Diameter, 5/8-11 Thread is ideal for use with a grinder or polisher
<b>11.8 mm CNC Porcelain Bit</b> SKU: CCH-KNBITCNC-11.8-D		11.8 mm 1/2 GAS CNC Bit for Porcelain
<b>11.4 mm Manual Porcelain Bit</b> SKU: CCH-KNBITGRI-11.4-D		11.4 mm Manual Porcelain Bit 11.4 mm Diameter, 5/8-11 Thread Porcelain Bit for Drilling Machine
<b>Go/No-Go Hole Tester/Depth Gauge</b> SKU: CCH-KNGAUGE		Tool used to check the diameter and depth of each drilled hole prior to pressing-in <b>KEEP-NUT™</b> (highly recommended when manually drilling)
<b>Insertion/Setting Tool</b> SKU: CCH-KNGAUGE		Insertion tool for <b>KEEP-NUT™</b> to deflect impact from mallet when pressing <b>KEEP-NUT™</b> into surface.

### Full Sink Mounting Sets:

<b>Full KEEP-NUT™ Set</b> SKU: CCH-KEEPNUT-1/4-KIT		All items needed for <b>KEEP-NUT™</b> Sink Anchors Including: <ul style="list-style-type: none"> <li>IM2S/P1.4-20/H6 <b>KEEP-NUT™</b></li> <li>Z-Shaped Sink Clip</li> <li>1 1/4" Length Post</li> <li>Wingnut and Washer</li> </ul>
<b>Full KEEP-NUT™ 100 pc Starter Set w/Tooling</b> SKU: CCH-KEEPNUT-STRKIT 1		<b>KEEP-NUT™ 100 pc kit includes:</b> <ul style="list-style-type: none"> <li>100—IM2S/P1.4-20/H6 <b>KEEP-NUT™</b></li> <li>100—Z-Shaped Sink Clip</li> <li>100—1 1/4" Length Post</li> <li>100—Wingnut and Washer</li> <li>Drill Bit of Choice</li> <li>Go-No-Go Hole Tester</li> <li>Setting Tool</li> </ul>
<b>Full KEEP-NUT™ 500 pc Starter Set w/Tooling</b> SKU: CCH-KEEPNUT-STRKIT 5		<b>KEEP-NUT™ 500 pc kit includes:</b> <ul style="list-style-type: none"> <li>500—IM2S/P1.4-20/H6 <b>KEEP-NUT™</b></li> <li>500—Z-Shaped Sink Clip</li> <li>500—IM2S/P1.4-20/H6 <b>KEEP-NUT™</b></li> <li>500—Z-Shaped Sink Clip</li> <li>Drill Bit of Choice</li> <li>Go-No-Go Hole Tester</li> <li>Setting Tool</li> </ul>

See our complete line of **KEEP-NUT™** parts @ [chemical-concepts.com](http://chemical-concepts.com)

## KDM115: KEEP-NUT™ Drilling Machine w/Polisher

- High-speed electric motor for improved performance on porcelain, sintered stone, and all ultra-compact surfaces
- Improved depth stop for fast and accurate drilling
- 4-point slide mechanism for improved stability
- Precise drilling in the shop or on-site
- Interchangeable parts to convert to an electric motor or air-powered version

**Use 11.4 drill bits only with  
KEEP-NUT™  
DRILLING MACHINE**



**SKU: CCH-KN-KDM115**  
(Drilling Machine w/ Electric Polisher)

**SKU: CCH-KN-KDM52**  
(Vacuum Drill Stand Only)

**SKU: CCH-KN-KDM600E**  
(Electric Drill Only)



Supports up to  
562 lbs. per  
anchor



Ventilated Facades



Under-mount Sink Anchor



Panel and Ceiling Hanging



Faucet Hole Drilling

## Sink Clips and Glue-On Sink Anchors



**MOST POPULAR BONDING FASTENERS**

### Chem-Set™ BONDING FASTENERS & SINK CLIPS

Available in plated steel and stainless steel (plating meets European standards)  
Available in stainless steel, aluminum or zinc plated

#### M1-B38 Undermount Sink Clips



**SKU: CCH-M1-RB38**

- 50 or 100 pcs. bagged
- Available in 3/4" or 1"
- Use with **Chem-Set™ 633** or **Chem-Set™ 605** adhesives

(see adhesives below and undermount kits on next pages)

#### M1-T38 Undermount Sink Clips



**SKU: CCH-M1T38**

- 50 or 100 pcs. bagged
- Available in 3/4" or 1"
- Use with **Chem-Set™ 633** or **Chem-Set™ 605** adhesives

(see adhesives below and undermount kits on next pages)

#### Chem-Set™ Z-Shaped Sink Clips



Stainless Steel "Z" shape

**SKU: CCH732G-100**

- Sold in box of 50 or 100
- Use with **Chem-Set™ 633** or **Chem-Set™ 605** adhesives

(see adhesives below and undermount kits on next pages)

#### M1-B23 Undermount Sink Clips



**SKU: CCH-M1-B23**

- 50 or 100 pcs. bagged
- Available in 3/4" or 1"
- Use with **Chem-Set™ 633** or **Chem-Set™ 605** adhesives

(see adhesives below and undermount kits on next pages)

#### Chem-Set™ C-Shaped Sink Clips



Stainless Steel "C" shape

**SKU: CCH733G-100**

- Sold in box of 50 or 100
- Use with **Chem-Set™ 633** or **Chem-Set™ 605** adhesives

(see adhesives below and undermount kits on next pages)

#### Chem-Set™ L-Shaped Sink Clips



Stainless Steel "L" shape

**SKU: CCH735G**

- Sold in box of 100
- .75" x 2" x .08"
- Use with **Chem-Set™ 633** or **Chem-Set™ 605** adhesives

(see adhesives below and undermount kits on next pages)

#### Chem-Set™ L-Shaped Sink Clips



Stainless Steel "L" shape

**SKU: CCH736G**

- Sold in box of 100
- .75" x 1.5" x .08"
- Use with **Chem-Set™ 633** or **Chem-Set™ 605** adhesives

#### Chem-Set™ L-Shaped Sink Clips



Stainless Steel "L" shape

**SKU: CCH737G**

- Sold in box of 100
- 1.25" x 1.5" x .08"
- Use with **Chem-Set™ 633** or **Chem-Set™ 605** adhesives

**Sink clips and accessories used — See each page for recommended gun to use with adhesive**

### No Drilling Adhesives

See page ?

#### Chem-Set™ 633 Quick Set Epoxy

Quick Set Epoxy for use on porous substrates like Granite, Marble, Concrete and Wood.

- Available in 25 ml & 50 ml

**SKU: CCA633**

OPAQUE



FOR NATURAL STONE

#### Chem-Set™ 605 Quick Set Acrylic

Acrylic adhesive for use on Solid Surface, Engineered Stone, Plastics and Metals.

- Available in 25 ml & 50 ml

**SKU: CCA605**

WHITE/CLEAR



FOR SOLID SURFACE AND ENGINEERED STONE

Most popular bonding fasteners and sizes illustrated. See website for our complete line of fasteners @ [chemical-concepts.com](http://chemical-concepts.com)

# COUNTERTOP FABRICATION

## Glue-On Sink Anchor Kits



### Chem-Set™ Undermount Kits For Natural Stone Surfaces and Engineered Stone

**Chem-Set™**  
**CCH740K**  
SKU: CCH740K

FOR NATURAL STONE



KIT INCLUDES: CCH740K
(1) 633 50ml Tube
(4) M1-RB38-1/4-20x0.75" Studs
(4) Z-Shaped Sink Clips
(4) Wingnuts
(4) Washers
(2) FICT Dishwasher Fasteners
(1) 50ml Dispense Gun
(2) Extra Mixing Nozzles

- Use with natural stone (granite, marble, concrete, wood)

**Chem-Set™**  
**CCH742K**  
SKU: CCH742K

FOR NATURAL STONE



KIT INCLUDES: CCH742K
(1) 633 25ml Hand Syringe
(4) M1-RB38-1/4-20x0.75" Studs
(4) Z-Shaped Sink Clips
(4) Wingnuts
(4) Washers
(2) FICT Dishwasher Fasteners
(2) Mixing Stick
(2) Mixing Cups

- Use with natural stone (granite, marble, concrete, wood)

**Chem-Set™**  
**CCH741K**  
SKU: CCH741K

FOR SOLID SURFACE AND ENGINEERED STONE



KIT INCLUDES: CCH741K
(1) 605 50ml Tube
(4) M1-RB38-1/4-20x0.75" Studs
(4) Z-Shaped Sink Clips
(4) Wingnuts
(4) Washers
(2) FICT Dishwasher Fasteners
(1) 50ml Dispense Gun
(4) Extra Mixing Nozzles

- Use with solid surface and engineered stone

FOR SOLID SURFACE AND ENGINEERED STONE

**Chem-Set™**  
**CCH743K**  
SKU: CCH743K



KIT INCLUDES: CCH743K
(1) 605 25ml Hand Syringe
(4) M1-RB38-1/4-20x0.75" Studs
(4) Z-Shaped Sink Clips
(4) Wingnuts
(4) Washers
(2) FICT Dishwasher Fasteners
(2) Mixing Stick
(2) Mixing Cups

- Use with solid surface and engineered stone



See our complete line of products @ [chemical-concepts.com](http://chemical-concepts.com)



# COUNTERTOP FABRICATION

## Glue-On Sink Anchor Kits cont'd

### Chem-Set™ Undermount Kits For Natural Stone Surfaces and Engineered Stone



**Chem-Set™**  
**CCH744K**  
SKU: CCH744K

KIT INCLUDES: CCH744K	
(1)	1" Threadlocker Post
(1)	Wingnut
(1)	Female Anchor

FOR NATURAL STONE



- Use with natural stone (granite, marble, concrete, wood)

**Chem-Set™**  
**CCH755K**  
SKU: CCH755K

FOR NATURAL STONE



KIT INCLUDES: CCH755K	
(100)	M1-RB38-1/4-20x1.00" Studs
(100)	Z-Shaped Sink Clips
(100)	Wingnuts
(100)	Washers

- Use with natural & engineered stone, or any solid surface top

## Undermount Sink Hardware

### Sinkits® Sink Mounting Clamp

- Clamp design for undermounting sinks to granite, quartz, concrete or any other stone or hard surface material
- Universal design works with all type sinks up to 3/4" thick rim
- Very strong — supports up to 117 pounds each



SKU: SIN-0911-48

### T31 TBolts Mechanical Flat Head Anchor

- 3/16" x 1 1/2"
- Stainless Steel
- Comes with nut and washer
- Anchoring system for undermount sinks
- 100 pcs. bagged



SKU: CCH-T31-3/16-1-1/2

### VANSEAL Sink Undermounter FULLY ADJUSTABLE AND REMOVABLE

- 25", 36", and 50" lengths easily trim to fit any cabinet size
- Eliminates the need for wood support
- Use side/side or front/back
- Hardware supplied for all installations
- Includes 2 rails, 4 mounting clips, 8 adjusting bolts/nuts, 2 joiner clips
- Sink Overflow Clips accessory: allows support for bowls with overflows with 2 sets of sink undermounters (includes 2 sliding clips, 2 adjusting bolts/nuts)

SKU: VAN-QN-UM

See our complete line of products @ [chemical-concepts.com](http://chemical-concepts.com)

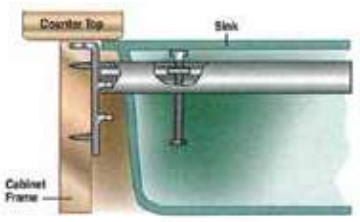
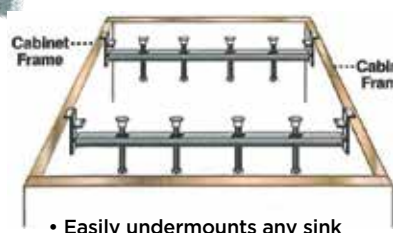

- Easily undermounts any sink including ovals and rounds
- Use with solid surface or granite countertop materials

- Eliminates the need for wood supports
- Saves time, money, and materials

(Two undermounter packages are needed for ovals and rounds)

## Dishwasher Mounting Bracket

### E-Z Dishwasher Bracket™

Available in 24" length



- Easy installation under any type of counter top
- Can be installed prior to or after counter top installation
- Dishwasher does not have to be present
- Made in USA from 22 gauge galvanized steel
- Available in 26 1/2" or 18" length

SKU: CCH-DWBAR

# COUNTERTOP FABRICATION

## CounterBalance® Float Frame Brackets

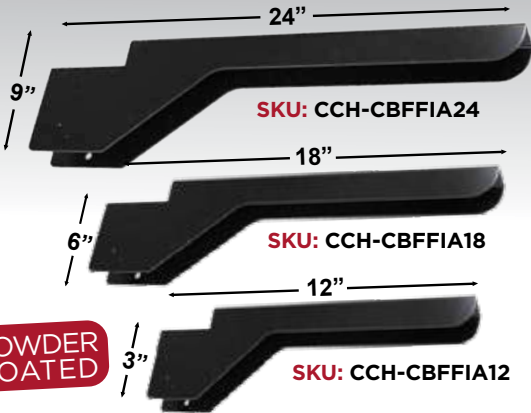

### CounterBalance®

<b>Material</b>	High Strength Steel (HRPO Steel*)
<b>Overhang Support</b>	Supports 12", 18" & 24" overhangs
<b>Mounting Holes</b>	3 Mounting Holes
<b>Width</b>	3" (95.25 mm) 6" (?? mm) 9" (?? mm)
<b>Length</b>	12" (304.8 mm) 18" (457.2 mm) 24" (610 mm)
<b>Thickness</b>	12 GA

### FLOAT FRAME Island Arm

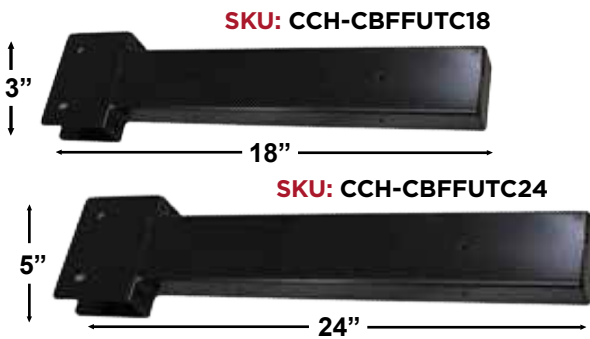

### CounterBalance®

<b>Material</b>	High Strength Steel (HRPO Steel*)
<b>Overhang Support</b>	Supports 18" & 24" overhangs
<b>Mounting Holes</b>	3 Mounting Holes
<b>Width</b>	3" (95.25 mm) 5" (127 mm)
<b>Length</b>	18" (457.2 mm) 24" (610 mm)
<b>Thickness</b>	12 GA

### FLOAT FRAME Under-The-Counter



See our complete line of CounterBalance® products @ [chemical-concepts.com](http://chemical-concepts.com)

## CounterBalance® Flat Plates and Half-Wall Overhang Brackets

POWDER COATED



### CounterBalance®

### COUNTERPLATE

<b>Material</b>	High Strength Steel (HRPO Steel*)
<b>Overhang Support</b>	Supports 13" overhangs
<b>Mounting Holes</b>	3 Mounting Holes
<b>Width</b>	3 3/4" (95.25 mm)
<b>Length</b>	9 3/4" (247.7 mm)
<b>Thickness</b>	7 GA

POWDER COATED



### CounterBalance®

### COUNTERPLATE XL

<b>Material</b>	High Strength Steel (HRPO Steel*)
<b>Overhang Support</b>	Supports 15" overhangs
<b>Mounting Holes</b>	3 Mounting Holes
<b>Width</b>	3 3/4" (95.25 mm)
<b>Length</b>	11 3/4" (298.5 mm)
<b>Thickness</b>	7 GA

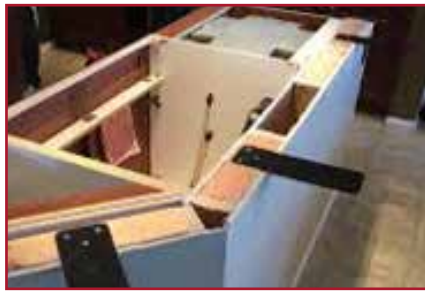

### CounterBalance®

### STAINLESS STEEL COUNTERPLATE & COUNTERPLATE XL

<b>Material</b>	304 stainless steel
<b>Overhang Support</b>	Supports 13" & 15" overhangs
<b>Mounting Holes</b>	3 Mounting Holes
<b>Width</b>	3 3/4" (95.25 mm)
<b>Length</b>	9 3/4" (247.7 mm) & 11 3/4" (298.5 mm)
<b>Thickness</b>	7 GA



See our complete line of CounterBalance® products @ [chemical-concepts.com](http://chemical-concepts.com)

## CounterBalance® Cabinetry Overhangs



**POWDER COATED**

SKU: CCH-CBIB2

### CounterBalance® ISLANDBAR (24")

<b>Material</b>	High Strength Steel (HRPO Steel*)
<b>Overhang Support</b>	Supports 18" overhangs
<b>Mounting Holes</b>	2 Mounting Holes
<b>Width</b>	1 ½" (38.1 mm)
<b>Height</b>	1 ½" (38.1 mm)
<b>Length</b>	24" (610 mm) long
<b>Thickness</b>	7 GA



**POWDER COATED**

- Corners are rounded for safety
- Available in kits of 3



SKU: CCH-CBIBM



### CounterBalance® ISLANDBAR MINI (20")

<b>Material</b>	High Strength Steel (HRPO Steel*)
<b>Overhang Support</b>	Supports 15" overhangs
<b>Mounting Holes</b>	2 Mounting Holes
<b>Width</b>	1 ½" (38.1 mm)
<b>Height</b>	1 ½" (38.1 mm)
<b>Length</b>	20" (508 mm) long
<b>Thickness</b>	7 GA



See our complete line of CounterBalance® products @ [chemical-concepts.com](http://chemical-concepts.com)

## CounterBalance® Cabinetry Overhangs

**POWDER COATED**

SKU: CCH-CBXB2

AVAILABLE COLOR:  Black



### CounterBalance® CROSSBAR (24" x 24")

<b>Material</b>	High Strength Steel (HRPO Steel*)
<b>Overhang Support</b>	Supports 18" overhangs
<b>Mounting Holes</b>	2 Mounting Holes
<b>Width</b>	1 ½" (38.1 mm)
<b>Height</b>	1 ½" (38.1 mm)
<b>Length</b>	24" x 24" length (610 mm x 610 mm)
<b>Thickness</b>	7 GA

**POWDER COATED**

SKU: CCH-CBXB2M2

AVAILABLE COLOR:  Black



### CounterBalance® CROSSBAR MINI (18" x 18")

<b>Material</b>	High Strength Steel (HRPO Steel*)
<b>Overhang Support</b>	Supports 15" overhangs
<b>Countersink Holes</b>	2 Mounting Holes
<b>Width</b>	1 ½" (38.1 mm)
<b>Height</b>	1 ½" (38.1 mm)
<b>Length</b>	18" x 18" length (457.2 mm x 457.2 mm)
<b>Thickness</b>	7 GA



See our complete line of CounterBalance® products @ [chemical-concepts.com](http://chemical-concepts.com)

## CounterBalance® Floating Countertop Brackets



### CounterBalance® CONCEALED BRACKETS

- Low-profile brackets provide a clean, “floating” look for your countertop
- Available lengths: 9”, 12”, 18”, and 24”
- Supports should be placed every 16” to 20”
- Available colors: white, black, grey and almond

**SKU: CCH-CBCB**

**AVAILABLE COLORS:**



White, Black, Grey and Almond

**Pictured: 18”**



### CounterBalance® EXTENDED CONCEALED BRACKETS

- Low-profile brackets provide a clean, “floating” look for your countertop
- Available lengths: 9”, 12”, 18”, and 24”
- Supports should be placed every 16” to 20”
- Available colors: white, black, grey and almond

**SKU: CCH-CBECB**

**AVAILABLE COLORS:**



White, Black, Grey and Almond

**Pictured: 9”**



### CounterBalance® CONCEALED FLAT BRACKETS

- Load limit range of 1400 lbs to 4900 lbs per pair
- Mounting hardware included
- Available lengths: 9”, 12”, 18”, and 24”
- Supports should be placed every 16” to 20”
- Available colors: white, black

**SKU: CCH-CBCFLAT**

**AVAILABLE COLORS:**



White and Black

**Pictured: 24”**



**SKU: CCH-CBCEFLAT**

**AVAILABLE COLORS:**



White and Black

**Pictured: 24”**

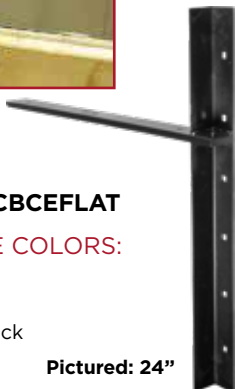

### CounterBalance® EXTENDED CONCEALED FLAT BRACKETS

- Upper extension (above the support arm) provides superior strength
- Load limit range of 1400 lbs to 4900 lbs per pair
- Mounting hardware included
- Available lengths: 9”, 12”, 18”, and 24”
- Supports should be placed every 16” to 20”
- Available colors: white, black

See our complete line of **CounterBalance®** products @ [chemical-concepts.com](http://chemical-concepts.com)

## CounterBalance® Floating Countertop Brackets

### CounterBalance® WORKSTATION BRACKETS



**POWDER COATED**

**SKU: CCH-CBWB**



- Handicap accessible vanities and workstations
- Stone and solid surface
- Weight Bearing Shelving
- 1/8" steel construction
- Very strong - exceeds - 1,000 lbs load limit
- 1 1/2" mounting surface with multiple 1/4" holes per side
- Standard color textured powder coat finishes

**AVAILABLE COLORS:**



Black, White, Gray, Almond, Stainless Steel and Pre-primed for your own finish

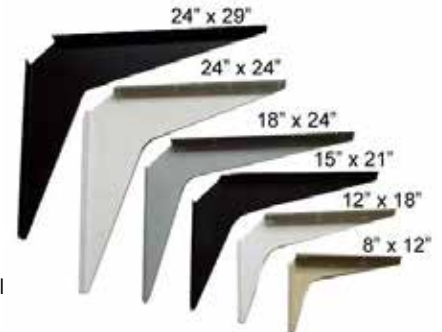

**SKU: CCH-CBADA**



Black, White, Stainless Steel

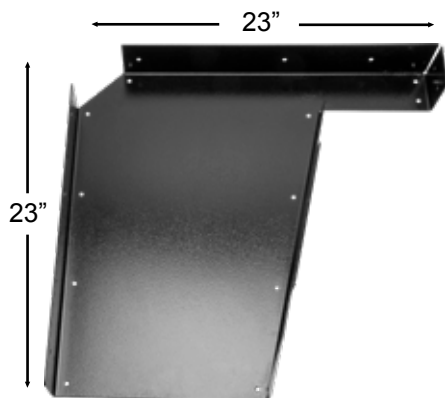

### CounterBalance® ADA VANITY BRACKETS

- 12 Gauge Steel offers superior strength
- Optional mounting holes on sides of Black Brackets to install your finishing panel if desired
- Accommodates 22" to 26" deep countertops
- No visible fasteners
- No tools required to remove & reinstall skirt
- Mounting holes provided
- 3x3 cut out for wall cleat & wire run clearance
- Standard color textured powder coat finishes: Black, white, gray, stainless steel and pre-primed for your own finish

- 21" length 533.4mm
- 22" height 558.8mm
- 3" width 76.2mm

- 23" length 584.2mm
- 22" height 558.8mm
- 3" width 76.2mm

- Available in the US or Import

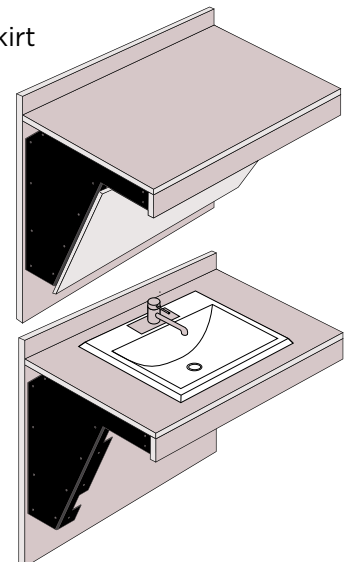

See our complete line of **CounterBalance®** products @ [chemical-concepts.com](http://chemical-concepts.com)

## CounterBalance® Floating Countertop Brackets

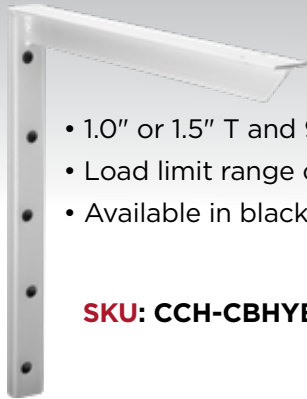

- 1.0" or 1.5" T and 9", 12", 18", and 24" support arms
- Load limit range of 525 lbs. to 2,200 lbs. per pair
- Available in black and white powder coat

**SKU: CCH-CBHYB**



### CounterBalance® HYBRID BRACKET

<b>Width</b>	1" or 1 ½" (38.1 mm)
<b>Height</b>	1 ½" (38.1 mm)
<b>Length</b>	18" x 18" & 18" x 24" lengths

- Finishing caps provided

### CounterBalance®

### HEAVY DUTY HYBRID BRACKET

<b>Width</b>	3" (72 mm)
<b>Height</b>	1" (24 mm)
<b>Length</b>	18" x 18" & 24" x 24" lengths

- Recommended double stud for bracket attachment
- Brackets available in black and white powder coat
- Available with 18" or 24" support arm
- 18" tall x 18" projection x 3" wide and 24" tall x 24" projection x 3" wide
- 1700 lbs./pr 18", 1350 lbs. /pr 24"
- Packed: 2 Per Box

- Finishing caps provided



AVAILABLE COLORS:    
White and Black

**SKU: CCH-CBHDHYB**



**SKU: CH-CBFV18-WH**

AVAILABLE COLORS:    
White Black

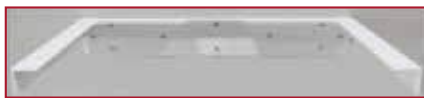

### CounterBalance®

### FLOATING VANITY BRACKETS

<b>Material</b>	.25" Steel—Extremely Strong
<b>Overhang Support</b>	Supports 18" overhangs
<b>Load limit</b>	1100 lb load limit
<b>Tall</b>	2" (50.8 mm)
<b>Wide</b>	28" (711.2 mm)
<b>Projection</b>	18" (457.2 mm) arm projection

- Blocking across back plate recommended
- 1 pc/21 lbs

See our complete line of **CounterBalance®** products @ [chemical-concepts.com](http://chemical-concepts.com)



## CounterBalance® Shelving Brackets

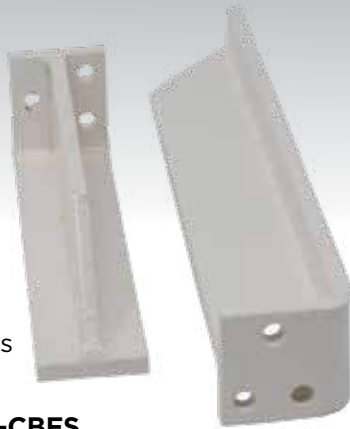

\*sold in pairs

**SKU: CCH-CBFS**

AVAILABLE COLOR:  White



**SKU#'s for available sizes:**

**SKU: CCH-CBFS6-IM**                      **2 pc/3 lbs**  
**SKU: CCH-CBFS9-IM**                      **2 pc/4 lbs**  
**SKU: CCH-CBFS12-IM**                      **2 pc/5 lbs**

### FLOATING SHELF BRACKETS

#### CounterBalance®

<b>Material</b>	.25" Steel—Extremely Strong
<b>Tall</b>	1 ¾" (44.45 mm)
<b>Thickness</b>	.25" thick (6.35 mm)
<b>Wide</b>	1 ½" (38.1 mm)
<b>Length</b>	6", 9" and 12" lengths

- **Load Limit:** 2000 lbs/pr 6", 1500 lbs/pr 9" and 1000 lbs/pr 12"
- Brackets must be mounted directly to the stud for maximum strength
- Mounting hardware will fail before bracket
- Brackets can be hidden in a boxed shelf

### HIDDEN SHELF BRACKETS

#### CounterBalance®



**SKU: CCH-CBHS**

AVAILABLE COLOR:  White



<b>Material</b>	.25" Steel—Extremely Strong
<b>Tall</b>	1 ½" (38.1 mm)
<b>Thickness</b>	.25" thick (6.35 mm)
<b>Wide</b>	20" (508 mm)
<b>Length</b>	6", 9" and 12" lengths

- **Load Limit:** 450 lbs/pr 6", 400 lbs/pr 9" and 350 lbs/pr 12"
- Blocking across back plate recommended
- Brackets can be hidden in a boxed shelf

**SKU#'s for available sizes:**

**SKU: CCH-CBHS6**                              **1 pc/5 lbs**  
**SKU: CCH-CBHS9**                              **1 pc/7 lbs**  
**SKU: CCH-CBHS12**                              **1 pc/8 lbs**

See our complete line of CounterBalance® products @ [chemical-concepts.com](http://chemical-concepts.com)

## CounterBalance® Surface, Stair & Cleat Brackets



SKU#'s for available sizes:

SKU: CCH-CBSF6  
SKU: CCH-CBSF9

SKU: CCH-CBSF12  
SKU: CCH-CBSF15

### SURFACE MOUNTED FLAT BRACKET

#### CounterBalance®

<b>Material</b>	Black powder coated steel
<b>Mounting Holes</b>	4 Mounting Holes
<b>Size</b>	6" 9" 12" and 15"
<b>Thickness</b>	1/2" thick steel

- A simple, strong and attractive alternative for floating shelves
- 1/2" thick material with 1/4" mounting holes
- Also available is Stainless steel and Aluminum, both brushed with clear finish



SKU: CCH-CBST10

### STAIR TREAD BRACKET

#### CounterBalance®

<b>Material</b>	Black powder coated steel
<b>Mounting Holes</b>	3 Mounting Holes
<b>Size</b>	10" by 2" support
<b>Thickness</b>	1/4" thick steel

- Heavy duty support for industrial style design treads
- Can be mounted either direction



SKU#'s for available sizes:

SKU: CCH-CBCLT28  
SKU: CCH-CBCLT44

SKU: CCH-CBCLT90

### CLEAT SUPPORT BRACKET

#### CounterBalance®

<b>Material</b>	Black powder coated steel
<b>Mounting Holes</b>	Holes offset at 8 inch intervals
<b>Size</b>	28", 44" and 90"
<b>Thickness</b>	1/4" thick steel

- Black Powder coated metal
- Countertop support for side walls and along back edge



SKU: CCH-CBISLB3-15

### ISLAND BRACKET

#### CounterBalance®

<b>Material</b>	Black powder coated steel
<b>Mounting Holes</b>	10 or 16 holes, offset at 1.3" intervals
<b>Size</b>	15", 34" and 40"
<b>Thickness</b>	1/2" thick steel

See our complete line of CounterBalance® products @ [chemical-concepts.com](http://chemical-concepts.com)

## Sealers and Cleaners



**WORLD LEADING SEALERS FOR THE PROTECTION OF NATURAL STONE, TILES, PAVERS CONCRETE, BRICKS AND GROUT.**

by **DRY TREAT**



**Premium Impregnating Sealer**  
*Previously known as STAIN-PROOF ORIGINAL™*  
Permanent-bonding impregnating sealer designed for use as premium stain protection.

- Premium permanent stain protection
- Superior oil and water repellence
- Retains natural surface and color
- Stands up to commercial cleaning methods

**15 YEAR WARRANTY**

**SKU: DRY110513**



**Porcelain & Quartz Sealer**  
*Previously known as PORCELAIN PLUS*  
Specifically designed for porcelain and quartz surfaces.

- Seals micro pores unpolished porcelain and quartz surfaces
- Creates a unique molecular bond
- Permanent, long lasting protection

**10 YEAR WARRANTY**

**SKU: DRY110600**



**Daily Countertop Cleaner**  
*Previously known as REJUVENATA™ SPRAY*  
A gentle daily cleaner for natural and engineered stone countertops used to keep countertops looking their best.

- Powerful, natural active enzyme cleaner
- For interior and exterior uses
- Hydrogen peroxide based
- For extra cleaning power, add SMC Peroxide Cleaner Additive!

**SKU: DRY141112**



**Acidic Cleaner**  
*Previously known as EFF-ERAYZA™*

Removes efflorescence grout haze, rust marks, limescale, soap scum, fireplace soot and mortar residue.

- The power of Muriatic acid without the fumes
- Chemically etches acid sensitive surfaces for added traction

**SKU: DRY141942**



**Alkaline Cleaner**  
*Previously known as OXY-KLENZA™*

A powerful triple action, oxygen, alkaline and detergent boosted heavy duty cleaner for removal of stains caused by oil / grease, mold, leaf marks, food and beverages.

- Up to 500 sq. ft. of peroxide cleaning power

**SKU: DRY141212**



**40SK Consolidator & Water Repellent**  
*Previously known as Dry Treat 40SK)*  
Deep color enhancement and premium stain protection.

- Designed for indoor and outdoor surfaces
- Breathable: water vapor escapes freely, avoiding moisture build-up inside the material
- Deep penetration and long lasting

**15 YEAR WARRANTY**

**SKU: DRY123142**



**SMC Peroxide Cleaner & Additive**  
*Previously known as S-TECH STONE & MASONRY CLEANER™ and SMC BOOST*

Penetrating, foaming dirt lifting action.

- For organic stains
- Ideal for historic preservation
- For interior and exterior uses
- Hydrogen peroxide based
- Add for extra cleaning power!

**SKU: DRY152000**



**Paver Enhancing Sealer**  
Offers both rich both rich color enhancement and water and liquid protection through a patented combination of silicone technology.

- Long-lasting, penetrating oil and water repellent
- Deepens and enriches the natural color of concrete pavers, cement tiles, terrazzo floors and cement surfaces

**SKU: DRY1508**

See our complete line of sealers and cleaners @ [chemical-concepts.com](http://chemical-concepts.com)



# ADVANCED HYBRID ADHESIVE

Most eco-friendly adhesives don't have the strength to get the job done. BoaBond Fast Cure offers an eco-friendly option that is made to perform on a wide variety of substrates.

- ✓ INNOVATIVE HYBRID TECHNOLOGY
- ✓ VOC COMPLIANT
- ✓ PERMANENTLY FLEXIBLE
- ✓ BONDS TO WET SURFACES

## BOABOND FEATURES

- Fast grab adhesive for easy vertical installation
- High strength, tough, durable bonds
- No solvents or Isocyanates for VOC compliance
- Bonds wet or damp materials
- Can be applied overhead with no sag
- 100% solids, will not shrink
- Fast cure offers immediate green strength
- Adheres to a wide variety of substrates
- Permanently flexible; allows for vibration & movement

## CONFORMS, MEETS & EXCEEDS

Conforms to California Proposition 65

Conforms to USDA requirements for non-food contact

Meets requirements of CARB & SCAQMD

VOC Compliant (9.55 grams/liter ASTM D2369)



**FOR MORE INFORMATION, CONTACT US AT:**

**1-800-220-1966 OR SALES@CHEMICAL-CONCEPTS.COM**

## Sealants

### Hybrid Sealants

Hybrids are silane-crosslinking organic polymers that combine properties typical of both silicone and polyurethane while eliminating their individual inherent weaknesses. Thus, hybrid sealants combine the adhesive strength and paintability of polyurethane with the weathering resistance of silicones.

“Silicone on Steroids”



**ULTRA CLEAR**

SKU: CCS-MS35-UC



**WHITE**

SKU: CCS-MS35-WT-10OZ

**Chem-Set™**

**MS-35 ULTRA CLEAR** 24 tubes per case

**Chem-Set™**

**MS-35 WHITE** 24 tubes per case

- Available in 10.3 standard caulking cartridge
- 2 times the bond strength of silicone - Lap shear 250-330 PSI
- 100% VOC HAPS/Compliant -75°F to 250°F (operating temp range)

	Work Time	Color
<b>Size</b>	10.3 Cartridge	
<b>Gun</b>	250 GUN Thrust Caulk Gun 18:1	
	SKU: NEW-250 250 ml	
<b>Cure</b>	Tack time: 2 hours. Full Cure: 24 hours.	

### Siliconized Acrylic Latex



SKU: CCS-PB3

AVAILABLE COLORS:



SKU: CCS-PB3 CLEAR

SKU: CCS-PB3 WHITE

**Chem-Set™ PB-3**

- One-component, latex sealant
- Paintable, mildew resistant and non-yellowing
- Water clean up

SKU: CCS-PB3 ALMOND

	Work Time	Color
<b>Size</b>	10.3 Cartridge	
<b>Gun</b>	250 GUN Thrust Caulk Gun 18:1	
	SKU: NEW-250 250 ml	
<b>Cure</b>	Tack time: 2 hours. Full Cure: 24 hours.	

### Polyurethane Construction Adhesive



AVAILABLE COLORS:



SKU: SIK91017 WHITE

SKU: SIK91013 COLONIAL WHITE

SKU: SIK91009 ALUMINUM GRAY

SKU: SIK91011 BLACK

- Non-sag elastomeric sealant
- Excellent resistance to aging, weathering paintable
- Certified NSF/ANSI standard for potable water and jet fuel resistant
- High elasticity

	Work Time	Color
<b>Size</b>	10.3 Cartridge	
<b>Gun</b>	250 GUN Thrust Caulk Gun 18:1	
	SKU: NEW-250 250 ml	
<b>Cure</b>	Tack time: 2 hours. Full Cure: 24 hours.	

See our complete line of adhesive sealants @ [chemical-concepts.com](http://chemical-concepts.com)

# COUNTERTOP FABRICATION

## Silicone - 100% RTV

### Chem-Set™ RTV3500 & RTV4500

Chem-Set™ RTV 4500 is a one component room temperature vulcanizing (RTV) industrial/construction grade silicone sealant and adhesive that has been chemically formulated for high strength adhesion.

- High Strength
- Excellent Weatherability
- UV Stable
- Non-Yellowing
- VOC Compliant
- Non-Flammable
- Waterproof
- Excellent Adhesion
- Non-Shrinking



#### Chem-Set™ RTV3500

Available Colors:



- ALUMINUM
- BLACK
- BRONZE
- CAMEO WHITE
- CLEAR
- GRAY
- TAUPE
- TRANS/WHITE
- WHITE

#### Chem-Set™ RTV4500

Available Colors:



- ALMOND
- TRANS/BEIGE
- TRANS/BLUE
- TRANS/BROWN
- TRANS/CHARCOAL
- TRANS/EARTHTONE
- TRANS/GRAY
- TRANS/GREEN
- TRANS/ROSE



### Sikasil GP-101 Formerly Bondaflex 100

SikaSil-GP is a general-purpose, one-component, non-sag, elastomeric, 100% RTV acetoxysilicone sealant. Standard 51 for direct food contact and California Air Resources Board 2003 requirements for Volatile Organic Compound content.

	Work Time	Color
Size	10.3 Cartridge	
Gun	250 GUN Thrust Caulk Gun 18:1	
	SKU: NEW-250 250 ml	
Cure	Tack time: 2 hours. Full Cure: 24 hours.	

- One-component ready to use
- Excellent for dynamic joint movement & dissimilar materials, Joint movement 325%
- Excellent adhesion, bonds to many substrates without priming
- Fast Cure - Move assembled or sealed parts quickly
- Wide service temperature / durability
- Superior gunning & tooling
- High temperature red for temperature resistance up to 550°F



Available Colors:

- WHITE
- BONE
- TRANS/WHITE
- CLEAR

See our complete line of adhesive sealants @ [chemical-concepts.com](http://chemical-concepts.com)

## Chip Repair Kits

### Chem-Set™ Chip Repair Kit

The Chem-Set **800** Chip Repair Kit repairs scratches, chips, holes, cracks, nicks, and fissures in stone quickly, making it perfect on on-site repairs. Ideal for natural stones, such as granite or marble.

#### PERMANENT REPAIR

- Quickly repairs chips, gouges, and small cracks on the job.
- Does not fracture or crack.
- Non-yellowing, UV stable.
- For Shop Use or Retail\*



Packaging

#### KIT INCLUDES: CCA800

(1 oz) Bottle of Thin Set (**CA5**)

(1 oz) Bottle of Thick Set (**CA2400**)

(2 oz) Bottle of Quick-Tac 2 'Low Bloom' Activator



SKU: CCA800

### Chem-Set™ Low Bloom Chip Repair Kits

The Chem-Set Low Bloom **801** and **802** Chip Repair Kits come with our new 'Low Bloom' Stone-Tac Activator which significantly decreases the occurrence of stone blooming or "greening" compared to the standard CA (super glue) kits out there today.

These kits allow you to make a variety of repairs on natural and engineered stone surfaces, with a significantly decreased chance of blooming or stone discoloration. • For Shop Use or Retail\*



#### Chem-Set™ Stone Tac 801 Kit

#### KIT INCLUDES: CCA801

(1 oz) Bottle of Thin Set (**CA5**)

(1 oz) Bottle of Thick Set (**CA-2400**)

(6 oz) Aerosol Can of Stone-Tac 'Low Bloom' Activator

Repair chips, gouges and small cracks on your stone surfaces.



SKU: CCA801

#### Chem-Set™ Stone Tac 802 Kit

#### KIT INCLUDES: CCA802

(1 oz) Bottle of Thin Set (**CA5**)

(1 oz) Bottle of Medium Set (**CA-100**)

(1 oz) Bottle of Thick Set (**CA-2400**)

(6 oz) Aerosol Can of Stone-Tac 'Low Bloom' Activator



SKU: CCA802



\*Private Labeling Available

## Chip Repair Kits

### Chem-Set™ UV Stone Repair Kits

ChemSet™ **UV Stone Repair Kits** are used when a fast permanent repair is needed to fix scratches, chips, gouges, holes, cracks and nicks on natural and engineered stone. Fast repairs can be completed in less than three minutes, the manufacturer reports.

No More Discoloration/Blooming Issues! This easy-to-use UV Kit uses a UV light to cure the adhesive. Without the use of an activator spray as a curing agent you will never have issues with blooming again. Great for your lighter colored stones and marbles.

#### Chem-Set™ UV Stone Repair 10ml Consumer Kit



**KIT INCLUDES: CCA900**

- 1 (10ml) Bottle **UV386**
- 4 Cure sheets
- 2 Polish packs
- 1 LED keychain light
- 2 Straight edge razors

**SKU: CCA900**



#### Chem-Set™ UV Stone Repair 50ml Pro Kit



**KIT INCLUDES: CCA951**

- 1 (50ml) Bottle **UV386**
- 15 Cure sheets
- 15 Polish packs
- 1 Large LED Flashlight
- 3 AAA batteries
- 5 Straight edge razors

**SKU: CCA951**



**5x** the value  
of leading  
competitors!

Our 10ml bottles are 5x the size of their 2ml syringes.



**VS**





## Porcelain Scratch Repair



### Surface Renu Porcelain Scratch Repair Kit

SurfaceRenu™ offers a full line of products for the removal of scratches, and damage from most types of polished ceramic surfaces.

SurfaceRenu is the industry's premier solution for rapid scratch removal from polished ceramic without leaving trace marks or creating distortion. Our Professional Grade System is designed to repair the most common types of ceramic damage, by providing the operator a simple, effective way to quickly restore damaged ceramic to "like-new" condition. The system features simple-to-follow instructions and everything required except a sander/polisher.

Every Professional Grade System includes high quality and reliable components, offering unparalleled speed and success in repairing damaged ceramic.

#### RenuDisks®

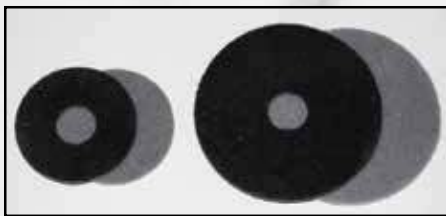

RenuDisks are available in two sizes (3" and 5") in two grinding ranges to match the type of surface damage being repaired.

The patented design and construction are proprietary to SurfaceRenu and available only through SurfaceRenu and Authorized SurfaceRenu Resellers. The disks employ a special construction that allows for rapid scratch removal from polished ceramic without leaving trace marks or discernible distortion — even on deep damage.

Instructions on when to use a particular disk size or grinding range are included with every SurfaceRenu System. The disks are color-coded for quick identification and ease of use. Selection by color helps to take the guesswork out of the scratch removal process.

#### RenuDisk Grinding Range Color Key:

**BLACK** Used for all damage that catches a fingernail

**GREY** Used to remove damage you can't feel with your fingernail and for Pre-polish

**SKU: SRN-108-1000**



**The SurfaceRenu Professional Grade System is a complete solution and includes:**

- High-end custom made backing pads—3" & 5"
- 40 RenuDisks®
- 2ct 5" Polishing felts
- 1—bottle of Light & Dark Polish Compound
- Rasp file
- Dust mask
- Easy to follow instructions

#### Surface Renu Polishing Compound

Each Professional Grade System comes with a bottle of SurfaceRenu's proprietary advanced formula Polishing Compound. We take rare earth mineral polish to a whole new level by refining and milling our own blend of polishing compounds to achieve the highest quality surface finish. One bottle of polish, filled with clean water to the top, will allow the user to polish up to 400 square feet of light damage from the ceramic surface.



• For Shop Use or Retail



See our complete line of SurfaceRenu™ products @ [chemical-concepts.com](http://chemical-concepts.com)

## Tape and Surface Protection Film

### Chem-Set™ Blue Painters Tape

The environmentally safe painter's tape will cleanly remove from most surfaces for up to 21 days, leaving clean, crisp paint lines.

**SKU: CCT-P621**

- Comes in sizes from 3/4" to 3"
- Works on a variety of surfaces
- Designed to prevent dry out or keep its holding power



### Alpha G-Tape

G-Tape is a patented combination of solvent acrylic adhesive with an advanced backing substrate that results in unmatched performance.

**SKU: CCT-G-TAPE**

- Waterproof
- Repositionable
- Great for quick repairs
- Hard surface protection
- Weather and UV resistant
- 2" X 163' (60 yds) multi-purpose tape
- Hand tears, straight and easy



### Chem-Set™ Masking Tape 5.0 mil

This all purpose masking is primarily used for general purpose bundling, packaging, protecting, and splicing.

**SKU: CCT-P217**

- Coated with natural rubber adhesive
- Excellent adhesive
- Temperature resistant
- Cream color



### Chem-Set™ Poly Film Mitre Tape

This 7 mil tape is excellent for mitreing offering the perfect combination of strength and durability.

**SKU: CCT-P74-2C**

- Use for mitreing
- 7 mil. Clear
- Size 2" X 60'



### tesa® Precision Mask

**tesa® 4334 3.5mil (.0035")**

**SKU: TES-4334**

The tesa Precision Mask 4334 reliably guarantees razor-sharp paint edges, and is extremely easy to use

- Yellow precision masking tape
- Suitable for precise applications
- Guarantees very sharp-edged finishing
- Suitable for delicate surface



### Chem-Set™ 3.0 & 4.0 mil Surface Protection Film

**SKU PRES30L40**

medium/high tack, 3 mil thick 24" x 600'

**SKU PRES30L40-30**

medium/high tack, 3 mil thick 30" x 600'

- Protect counters and porcelain/marble and granite pieces from damage during storage construction, and transportation
- Can be safely applied to the surface without damaging the counter or leaving residue
- Good for use on flat surfaces

**Available Sizes**  
Film 24" x 600' • 30" x 600'

**600 Foot Rolls**



### Chem-Set™ Foil Tape 3.0 mil

Aluminum Foil/Acrylic Adhesive

**SKU: CCT-AF30SW-2**

- Surface film protection
- Used for waterproofing, vapor barrier, and air leakage protection
- High reflectivity assures effective heat, light interference, and electrical insulation shielding
- Designed to stick firmly to it's own backing
- Great for installing cook tops in solid surface
- Premier product for masking in paint stripping and electroplating



See our complete line of **Chem-set™** tapes @ [chemical-concepts.com](http://chemical-concepts.com)

## Hot Melt Adhesives

### Chem-Set™ Hot Melt Adhesives

#### Chem-Set™ 735 Hot Melt

**SKU: FPC735R10, R15**

**Color: Amber/Clear**

- General purpose
- High strength
- Resists shock at low temperature
- 25 second open time
- Softening point: 185°F
- Application temperature: 325°F to 380°F



**AVAILABLE SIZES:**

1/2" x 10" or 15" • 5/8" x 10" or 15" • 3/4" x 10" or 15" • 1" x 10" or 15"

#### Chem-Set™ 725 Hot Melt

**SKU: FPC-725**

**Color: Clear**

- General purpose clear hot melt
- Designed to use low to high temperature glue gun
- Softening point: 176°F
- Open time: 65 seconds
- Application temperature: 250°F to 380°F

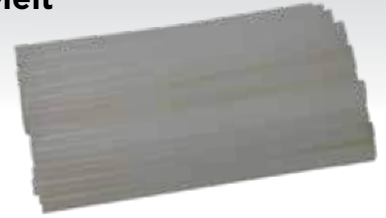

**AVAILABLE SIZES:**

1/2" x 10" or 15" • 5/8" x 10" or 15" • 3/4" x 10" or 15" • 1" x 10" or 15"

#### Chem-Set™ QUAD 701 Hot Melt

**SKU: FPC-QUAD-701 Fast Set**

**Color: Amber Quadrack Hot Melt**

- All temperature perfect for packaging and carton sealing
- 15 second open time
- Softening Point: 178°F
- Application temperature: 250°F to 380°F

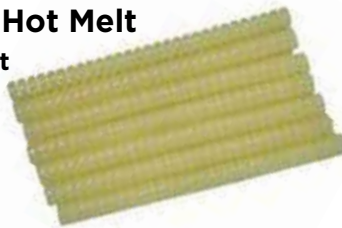

**AVAILABLE SIZES:**

1/2" x 10" or 15" • 5/8" x 2", 8" or 10"

#### Chem-Set™ QUAD 725 Hot Melt

**SKU: FPC-QUAD-725**

**Color: Clear Quadrack Hot Melt**

- All temperature perfect for packaging and carton sealing
- 60 second open time
- Softening Point: 178°F
- Application temperature: 178°F



**AVAILABLE SIZES:**

1/2" x 10" or 15" • 5/8" x 2", 8" or 10"

#### Chem-Set™ 707 Hot Melt

**SKU: FPC-707**

**Color: Amber**

- High performance glue stick formulated specifically for bonding difficult surfaces
- 30 second open time
- Softening Point: 178°F
- Application temperature: 380°F

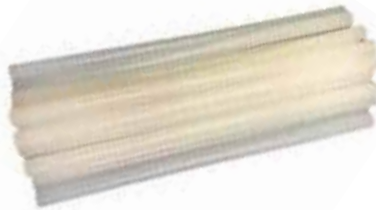

**AVAILABLE SIZES:**

1/2" x 10" or 15" • 5/8" x 10" or 15"

#### Chem-Set™ 711 Hot Melt

**SKU: FPC-711**

**Color: Opaque/Tan**

- Fast set packaging adhesive with excellent hot tack
- 15 second open time
- Softening point: 208°F
- Application Temperature: 380°F



**AVAILABLE SIZES:**

1/2" x 10" or 15" • 5/8" x 10" or 15" • 3/4" x 10" or 15"

#### Chem-Set™ 925 Hot Melt

**SKU: FPC925R10**

**Color: Clear**

- High strength for multiple applications developed for concrete, carpet, wood, glass and Ceramic
- Medium open time
- Softening point: 165°F
- Application Temperature: 350°F to 390°F



**AVAILABLE SIZES:**

1/2" x 10" or 15"

#### Chem-Set™ Hot Melt Chart

Suffix Letter	Diameter Size	Length
R10	1/2"	10"
R15	1/2"	15"
TC	5/8"	2"
Q	5/8"	10"
Quad	5/8"	8"
M	3/4"	2 1/2"
P	1 3/4"	1 3/4"

#### Box/Case Quantities

735R10/15	1/2" x 10"	5/25 Lb Box
725R10/15	1/2" x 10"	5/25 Lb Box
725R15	1/2" x 15	25 Lb Box
TC725/735	5/8" x 2"	20 Lb Box
Q725/735	5/8" x 10"	25 Lb Box
725R45	1/2" x 4"	5 Lb Box
725R45	1/2" x 4"	25 Lb Box
Quad-725	5/8" x 8"	11 Lb Box
M725	3/4" x 2 1/2"	35 Lb Box

*Other formulations available—call for more information*

Warning: Contact with skin can cause severe burns

See our complete line of hot melt adhesives @ [chemical-concepts.com](http://chemical-concepts.com)

## Dispense Guns Industrial

**Chem-Set™** Stocking Distributor: Adhesive Dispense Guns from Cox, Newborn, Sulzer and Albion. Manual & Pneumatic.

### DISPENSE GUNS

SEE EACH PAGE FOR RECOMMENDED GUN TO USE WITH ADHESIVE



50 ml

#### PAK-50 Dispense Gun

- Industry-standard applicator gun for 50ml double barrel cartridges
- Perfect for consistently applying Epoxy and Adhesives to your jobs
- Drip-free dispensing

SKU: CCH50G-1-1/2-1



50 ml

#### DS51

- 10:1 thrust ratio—50ml
- Sturdy, high-quality, compact
- Provides a convenient, cost-effective method to apply product with minimal waste

SKU: CON-DS51-10-00



200 ml

#### VR210XSP

- 10:1 Thrust ratio
- For use with 220ml mixpac and TAH cartridges
- Precision sintered friction plate

SKU: NEW-VR210XSP



400 ml

#### VR400XSP

- 26:1 Thrust Ratio
- Ratios of 10:1, 4:1, 2:1, and 1:1
- Extra Durable, Heat Treated Piston Rod
- Precision Sintered Friction Plate

SKU: NEW-VR400XSP



200 ml

#### DM2X 200

- Exceptional dispensing with full flexibility
- Unique dual drive mechanism
- Modern and Functional Design

SKU: CON-DM2X200-52-01



400 ml

#### DM2X 400

- Rigid tool frame
- Effortless operation
- Easily accessible controls

SKU: CON-DM2X400-60-01



200 ml

#### DP2X 200 Pneumatic

- Extraordinary precision
- Drip-free dispensing
- Fatigue free handling

SKU: CON-DP2X-200-25-01



400 ml

#### DP2X 400

- Extraordinary precision
- Drip-free dispensing
- Built-in silencer enables quiet operation

SKU: CON-DP2X-400-50-01



200 ml

#### VR200A83 Pneumatic

- Nominal Thrust 490 lbs.
- For Use with 200ml & 400ml Cartridges
- Mix Ratios of 1:1, 2:1, 4:1, and 10:1
- Adjustable Aluminum Air Regulator

SKU: NEW-VR200A83



400 ml

#### VR400A83 Pneumatic

- For Use with 200ml & 400ml Cartridges
- Mix Ratios of 1:1, 2:1, 4:1, and 10:1
- Slide In/Side Load
- Adjustable Aluminum Air Regulator

SKU: NEW-VR400A83



250 ml

#### 250 High Thrust Caulk Gun

- 18:1 thrust ratio
- For use with one part adhesives/sealants in 1/10 gal cartridges
- Revolving barrel

SKU: NEW-250



50 ml

DK Converter pictured inside 250 caulk gun

#### DK Converter

- Caulk Gun Adapter for use inside caulk gun
- For use with 50 ml cartridges
- Converts 50ml dual cartridges for use in standard 1/10th gal. guns

SKU: TAH-DK

#### 250ml Dispenser

- Compatible with Mixpac 250ml cartridges systems
- 18:1 mechanical advantage reduces fatigue
- Sturdy steel frame doesn't flex or bend



**Integra Adhesives**



#### 500ml Dispenser

- Compatible with many other 400ml/470ml cartridges
- 25:1 mechanical advantage reduces fatigue
- Steel push rods braced with reinforced plate to prevent off-ratio mixing

See our complete line of industrial dispense guns @ [chemical-concepts.com](http://chemical-concepts.com)

## Dispense Guns Hot Melt

### Chem-Set™ Hot Melt Adhesive Dispensing Guns

#### Hot Melt Dispense Guns



#### PRO2-220 Adjustable Temperature Glue Gun

220 WATTS



- Temperature adjustment from 248 °F to 428°F
- This gun uses standard (1/2", 7/16", 0.43") diameter glue sticks.
- Ergonomic finger trigger design for less effort
- Integrated gun balancer mount hole

**SKU: FPC-PRO2-220**

Includes: extra nozzles, detachable wire stand and storage case. Uses standard (1/2", 7/16", 0.43") diameter glue sticks. Interchangeable nozzles available.

#### PRO2-220HT High Temperature Glue Gun

220 WATTS



- Ergonomic finger trigger design for less effort
- Operating Temperature 380° F
- Stroke adjustment screw
- Integrated gun balancer mount hole
- Protective heat resistant nozzle cover
- Lighted On/Off switch

**SKU: FPC-PRO2-220HT**

Includes: extra nozzle, detachable wire stand and storage case. Uses standard 7/16" (.43") diameter glue sticks. Weight: 1.6 lbs. Interchangeable nozzles available.

#### HYBRID 120 Cordless Gun



- Can be used as a cordless glue gun or with the option to use an AC power cord with your glue gun
- 18V Ryobi sold separately which provides versatility and freedom of motion when needed.
- Battery lasts up to 1 hour
- Comes with heavy duty carrying case

**SKU: FPC-HYB120-KIT**

#### PRO2 60 Cordless Gun

60 WATTS



- 60-watt internal heater that allows to gun to reach the operating temperature of 380°F in a matter of 5-6 minutes
- 18V Ryobi sold separately which provides versatility and freedom of motion when needed.
- Run time of up to 1.5 hours on a 2.0Ah battery
- Lightweight, comfortable and will get the job done

**SKU: FPC-PRO2-60**

#### PRO2-100 High Temperature Glue Gun

100 WATTS



- Ergonomic comfort grip and long trigger
- Operating Temperature 380°F
- Protective heat resistant nozzle cover
  - Detachable wire stand
  - Interchangeable nozzle
  - On/Off switch

**SKU: FPC-PRO2-100** Uses standard 7/16" (.43") diameter glue sticks. Weight .90 lbs. Interchangeable nozzles available.

#### PRO2-80 Professional Glue Gun

80 WATTS



- Ergonomic comfort grip and long trigger
- Operating Temperature 380°F
- Protective heat resistant nozzle cover
- Detachable wire stand
- Insulated nozzle
- Uses 7/16 inch (.443) glue stick

**SKU: FPC-PRO2-80** Uses standard 7/16" (.43") diameter glue sticks. Weight 1.217 lbs. Interchangeable nozzles available.

#### PRO2-180 High Temperature Glue Gun

180 WATTS



- Ergonomic finger trigger design for less effort
- Operating Temperature 380° F
- Stroke adjustment screw
  - Integrated gun balancer mount hole
  - Protective heat resistant nozzle cover
  - Lighted On/Off switch

**SKU: FPC-PRO2-180** Uses standard 7/16" (.43") diameter glue sticks. Weight 1.3 lbs. Interchangeable nozzles available.

#### HE-750 Professional Glue Gun

80 WATTS



- Ergonomic comfort grip and long trigger
- Operating Temperature 380°F
- Dual Temp or High Temp
- 80 watt, 120V heater
- Gun rests on wire stand

**SKU: FPC-HE-750** Uses standard 7/16" (.43") diameter glue sticks. Weight .80 lbs. Interchangeable nozzles available.

#### PRO9700A Adjustable Temp Glue Gun

220/300 WATTS



- Ergonomic finger trigger design for less effort
- Temperature adjustment from 220° F to 400° F
- The 300 watt heater gives you greater glue output
  - Integrated gun balancer mount hole
  - Protective heat resistant nozzle cover
  - Lighted On/Off switch

**SKU: FPC-PRO9700A** (220 or 300 Watts) Includes: extra nozzle, detachable wire stand and storage case. Uses standard 7/16" (.43") diameter glue sticks. Weight: 1.6 lbs. Interchangeable nozzles available.

#### MGG-800 Double Motorized Professional Heavy Duty Hot Glue Gun

800 WATTS



- 800 Watts of continuous melting power
- Uses 5/8 Size Glue Sticks - This glue gun puts out high glue volumes which requires a bigger diameter glue stick
- Double Motorized Glue Gun - Glue Sticks are motor fed through two motors
- NO compressed air needed

**SKU: FPC-MGG-800**

See our complete line of hot melt adhesive dispensers @ [chemical-concepts.com](http://chemical-concepts.com)

## Abrasives and Pads

### Maroon Buff N Blend Non Woven Grip Back Discs - 320 A/O Grit

SIZE	PART NUMBER	DESCRIPTION	BOX QTY.
5"	05NWD707V	5" MAROON BUFF N BLEND GRIP DISCS	25
6"	06NWD707V	6" MAROON BUFF N BLEND GRIP DISCS	25
11"	11NWD707V	11" MAROON BUFF N BLEND GRIP DISCS	5



### Gray Buff N Blend Non Woven Grip Back Discs - 800 S/C Grit

SIZE	PART NUMBER	DESCRIPTION	BOX QTY.
5"	05NWD635V	5" GRAY BUFF N BLEND GRIP DISCS	25
6"	06NWD635V	6" GRAY BUFF N BLEND GRIP DISCS	25
11"	11NWD635V	11" GRAY BUFF N BLEND GRIP DISCS	5

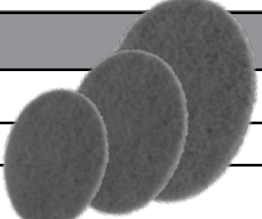



### Gold Buff N Blend Non Woven Grip Back Discs - 1200 A/O Grit

SIZE	PART NUMBER	DESCRIPTION	BOX QTY.
5"	05NWD636V	5" GOLD BUFF N BLEND GRIP DISCS	25
6"	06NWD636V	6" GOLD BUFF N BLEND GRIP DISCS	25
11"	11NWD636V	11" GOLD BUFF N BLEND GRIP DISCS	5





## Accessories

siaFast™ HOOK N' LOOP BACKUP PADS: 1 5/16" -24 THREAD	SIZE	GRADE	ARTICLE #.
	6" NO HOLE	3/8" THICK-FIRM LOW PROFILE	7486.5440.0000
	6" 54 HOLE	3/8" THICK-SOFT, LOW PROFILE 3/8" THICK-HARD, LOW PROFILE	0020.6734 0020.6735
	5" NO HOLE	1/2" THICK-SOFT EDGE 1/2" THICK-MEDIUM EDGE	0020.2039 4580.8409.0000
	5" 54 HOLE	3/8" THICK-SOFT, LOW PROFILE 3/8" THICK-HARD, LOW PROFILE	0020.6728 0020.6729
INTERFACE PADS	SIZE	GRADE	ARTICLE #.
	6" NO HOLE	3/8" THICK-FIRM LOW PROFILE	7486.5440.0000
	6" 54 HOLE	3/8" THICK-SOFT, LOW PROFILE 3/8" THICK-HARD, LOW PROFILE	0020.6734 0020.6735
	5" NO HOLE	1/2" THICK-SOFT EDGE 1/2" THICK-MEDIUM EDGE	0020.2039 4580.8409.0000
	5" 54 HOLE	3/8" THICK-SOFT, LOW PROFILE 3/8" THICK-HARD, LOW PROFILE	0020.6728 0020.6729

See our complete line of Chem-set™ Abrasives and Pads @ [Chemical-concepts.com](http://Chemical-concepts.com)

## Abrasives and Pads

### 1950 siaSpeed™ – at full speed to a perfect surface

1950 siaSpeed™ FiboTec™ siaFast™ Hook N' Loop Discs	SIZE	GRADE	ARTICLE #.
	6" FiboTec™ 59 hole	120	2279.5390.0120
		180	2279.5390.0180
		280	2279.5390.0280
		400	2279.5390.0400
		600	2279.5390.0600
	5" FiboTec™ 41 hole	120	4800.6167.0120
		180	4800.6167.0180
		280	4800.6167.0280
		400	4800.6167.0400
		600	4800.6167.0600
	SIZE	GRADE	ARTICLE #.
	6" no hole	120	7332.9183.0120
		180	7332.9183.0180
		280	7332.9183.0280
		400	7332.9183.0400
		600	7332.9183.0600
	5" no hole	1000*	7332.9183.1000
		120	6783.7705.0120
		180	6783.7705.0180
		280	6783.7705.0280
		400	6783.7705.0400
	600	6783.7705.0600	
	1000*	6783.7705.1000	



Blue  
11.25"  
Sanding Disc  
for  
Gem Sander

### Chem-Set™ 11" Orbital Gem Sander (Hook & Loop)

- Heavy-duty ball bearing capacitor motor
- No gears to grind or strip out
- No carbon brushes to burn out
- No armature winding to burn out
- Exclusive removable shaft system
- Sands, polishes and finishes. Best deal anywhere
- Available with HOOKIT or HOOKIT II pad

**FEATURES**

- Heavy-duty ball bearing capacitor motor
- No gears to grind or strip out
- No armature winding to burn out
- No carbon brushes to burn out
- Exclusive removal shaft system
- Sands, polishes and finishes

**SPECIFICATIONS**















Weight .....18 lbs.  
Overall height .....10in.  
Amps..... 2.3@110v, 1.2@220v  
RPM .....1,77@11v  
Moto ..... 110v/220v  
Housing.....heavy-duty aluminum

SKU: CCH-BW-HL

See our complete line of Chem-set™ Abrasives and Pads @ [Chemical-concepts.com](http://Chemical-concepts.com)

## Abrasives and Pads

### Blue Film Grip Disc

SIZE		H&L	PSA	GRIT RANGE	BOX QTY
3 1/2" X 7 HOLE FESTOOL		X	X	80-1000	100
3 1/2" X NO HOLE		X	X	80-2000	100
5" X NO HOLE		X	X	80-2000	100
5" X 5 HOLE		X	X	80-1000	100
5" X 8 HOLE BOSCH		X	X	40-220	100
5" X 9 HOLE FESTOOL		X	X	40-220	100
6" X NO HOLE		X	X	80-2000	100
6" X 6 HOLE BOSCH, RIGID, PORTER CABLE		X	X	40-220	100
6" X 8 HOLE FEIN		X	X	40-220	100
6" X 9 HOLE FESTOOL		X	X	40-220	100
6" X 15 HOLE UNIVERSAL HOLE PATTERN		X	X	40-220	100
8" X NO HOLE		X	X	80-2000	25
11" X NO HOLE		X	X	80-2000	25
11" X 5" DONUT HOLE		X	X	80-2000	25

See our complete line of Chem-set™ Abrasives and Pads @ [Chemical-concepts.com](http://Chemical-concepts.com)



## Contact Cements



### Tensorgrip® P300

#### High Temp General Purpose Contact Adhesive

Designed to deliver a smooth and strong bond in nearly any application.

- Fast, high tack
- Excellent green strength and high heat resistance (over 220°F/105°C)
- Fast drying with long open time
- Excellent high coverage

SKU: Q-P300



### Tensorgrip® P302

#### Non-Flam High Temp Contact Adhesive

Designed to be a versatile, safe and reliable adhesive.

- Excellent high coverage
- 80% of final strength immediately
- Full strength in 24 hours
- Fast drying with long open time
- Good heat resistance (up to 220°F/105°C)

SKU: Q-P302



### Tensorgrip® P307

#### Low VOC Contact Adhesive

Aggressive and versatile, bonding flexible and porous materials with ease.

- Excellent bonding to porous substrates
- Good heat resistance (up to 180°F/82°C)
- High-strength, long-term bond
- Strong initial bond
- Low VOC California Compliant (SCAQMD Rule 1168)

SKU: Q-P307



### Tensorgrip® P321

#### Polystyrene Foam Contact Adhesive

Designed as a portable, self-contained spray system for field or shop applications.

- Will not attack polystyrene
- Fast tack
- Water resistant
- No chlorinated solvents
- Permanent contact adhesive bond
- 80% of final strength achieved immediately
- Full strength achieved in 24 hours

SKU: Q-P321



### STA'-PUT® SP80

A high performance aerosol contact adhesive that can be used on a variety of substrates. It gives a water-resistant, non-staining bond for common HPL applications.

- Low VOC non chlorinated
- Quick Grab Tack
- High Strength bonds
- Use brush roller or spray
- Smooth, flat spray pattern
- High Green Strength
- OTC States Compliant
- Excellent adhesion to many substrates
- SCAQMD Compliant—Rule 1168

SKU: TACC-SP8028C



### STA'-PUT® S200

Specifically for bonding high pressure laminates to various substrates. Suitable for a variety of applications in woodworking, manufactured housing, general construction, recreational vehicle, marine, furniture, textile, HVAC upholstery and more.

- Aggressive Grab Tack
- Quick Dry Time
- Long Open Time
- High Green Strength
- Excellent adhesion to many substrates
- Flatwork Applications (non-postforming)
- Self-Contained Portable Spray System

SKU: TACC-S200-37C



### Chem-Set™ 315M

High solids contact bond adhesive in a non-flammable solvent. Formulated for use in bonding a wide variety of materials.

- Non-flammable
- Solvent based
- Spray grade
- Brush, roller, or spray
- Available in pails and drums
- Bonds plastic laminates, metals, foams, wood
- Low VOC/OTC compliant

SKU: AW315M-05C



### Chem-Set™ 205M

Non-flammable, solvent based, high performance contact adhesive suitable for bonding decorative laminate, wood, particleboard, metal, rubber, hardboard, plywood and many other materials.

- Neoprene runner based
- Post form grade
- Automotive vinyl
- Non-flammable
- Low VOC/OTC compliant
- Solvent based
- Long open time
- High temperature
- Brush, roller, or spray
- Available in pails and drums
- Bonds plastic laminates, metals, foams, and wood

SKU: CCN-205C

See our complete line of products @ [chemical-concepts.com](http://chemical-concepts.com)

## Polypropylene and Polyethylene Adhesives

### Chem-Set™ 6105 Fast Set



- 2-part, 1:1 toughened acrylic adhesive
- Bonds low surface energy plastics and a wide variety of other materials such as metals and composite materials
- Ideal for bonding dissimilar surfaces
- Working Strength: 2-4 hours • Viscosity @ 25°C: Mixed: 125,000cPs
- Service Temperature -55 to +100°C (-67 to +212°F)
- Fast set—Handling time: 20-25 minutes
- Fixture time—5-10 minutes • No primer required
- Polypropylene: 5-8 N/mm<sup>2</sup> (725-1,200 psi) Polyethylene: 3-6 N/mm<sup>2</sup> (435-870 psi)

**SKU CCA6105-50**

### Permabond®

## POP Polyolefin Primer

**SKU PER-POP-Primer**



### Durable Adhesive Repair

- Primer developed for surface treatment of polyolefins, PTFE and silicones prior to bonding with Permabond® cyanoacrylate adhesives
- Polyolefin primer create a durable bond stronger than the substrate material
- Surface Prep prior to bonding adhesive
- Available in 4oz and gallon

### Chem-Set™ 6110 Medium Set



- 2-part, 1:1 toughened acrylic adhesive
- Bonds low surface energy plastics and a wide variety of other materials such as metals and composite materials
- Ideal for bonding dissimilar surfaces
- Working Strength: 6-8 hours • Viscosity @ 25°C: Mixed: 210,000cPs
- Service Temperature -55 to +100°C (-67 to +212°F)
- Fast set—Handling time: 40-50 minutes
- Fixture time—12-15 minutes • No primer required
- Polypropylene: 5-8 N/mm<sup>2</sup> (725-1,200 psi) Polyethylene: 3-6 N/mm<sup>2</sup> (435-870 psi)

**SKU CCA6110-50**

**Great for producing exterior cabinetry made from Starboard or similar products**



Polyethylene lapshears bonded with CCA6110 the adhesive bond is so strong the plastic stretches, deforms, and fails before the bonded joint.

	Work Time	Color
	see above	Off-White
Size	50ml	400ml
Guns		 VR400XSP
Mixer	 CON-MBQ05-16L	 MFQX08-24T MFQ-08-24T
Cure	15 MINUTES AT ROOM TEMPERATURE	

See our complete line of polypropylene and polyethylene adhesives @ [chemical-concepts.com](http://chemical-concepts.com)





410 Pike Road • Huntingdon Valley, PA 19006

**TOLL FREE: 800.220.1966**

Phone: 267.684.1038 • Fax: 215.357.2754 • Email: [sales@chemical-concepts.com](mailto:sales@chemical-concepts.com)

[chemical-concepts.com](http://chemical-concepts.com)