

PERFORMANCE GUIDE

IM1763-78 Double Coated Foam Tape

Version: 3
Date: 3/2024
Approved by: JNP

Product Description

IM1763-78 consists of a 1/32" polyethylene foam carrier coated on both sides with 2.6 mils of high-performance rubber adhesive. The adhesive is protected by a two-side silicone coated 78# super-calendared Kraft liner. This product is designed for mounting applications that require high adhesion and superior shear strength.

Product Construction

- **Carrier:** 1/32" 6# PE Foam
- **Adhesive:** 2.6 mil MP555 Rubber Adhesive
- **Liner:** 78# White SCK
- **Web Width:** 60"

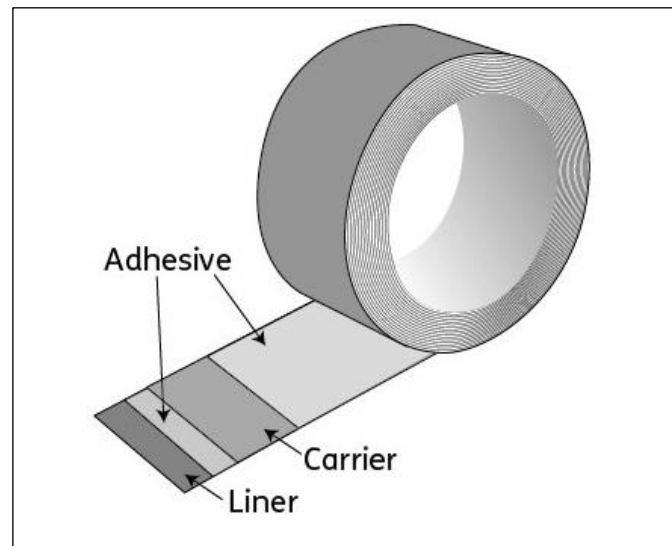

Features

- High performance rubber adhesive
- Excellent Shear Properties
- Robust release liner

Benefits

- High initial tack and adhesion
- Excellent adhesion to a wide variety of substrates
- Excellent handling and die-cutting.
- Permanent Interior Mounting adhesive

Applications

- General purpose mounting & bonding applications
- Dispenser Mounting
- Vibration damping and insulation
- Gap Filling
- Sign & Wayfinding Mounting

IM1763-78 Physical Properties			
Thickness	Mils Liner/Unwind		
Adhesive	2.6/2.6		
Carrier	31.25		
Liner	6.0		
Total Thickness	42.45		
Performance Test	Test Method	Typical Values	
Loop tack	PSTC-16	Lbs./in.	Oz/in.
Stainless Steel	2 mil PET Backed	10	160
Peel Adhesion	PSTC-101-Method A	Lbs./in.	Oz/in.
Stainless Steel	2 mil PET Backed	8	96
Shear	PSTC-107	Hours to Fail	
1 kg weight	72°F	500+	
Tensile	ASTM-D882	Lbs./in.	
MD/CD		129/96	
Elongation	ASTM-D882	%	
MD		232	

Values given are typical and not for use in specifications

SERVICE TEMPERATURE

Application: Above 50°F (10°C) for best performance
 End Use: -40°F to 190°F (-40°C to 88°C)

APPLICATION DETAILS

For best performance surfaces must be clean, dry and free of any oil, grease or other contaminant.

SHELF LIFE

Two-year shelf life when stored at 75°F. (24°C.) and 50% relative humidity or less. It is recommended that the product be stored in its original package until ready to use.

CALL **1-800-328-2619** for additional product information

IMPORTANT NOTICE: The information given and recommendations made herein are based on our research and are believed to be accurate. In every case, user shall determine before using any product in full scale production, whether such product is suitable for their particular purpose under their own operating conditions. User assumes all risk and liability whatsoever in connection with their use of any product. The products discussed herein are sold without any warranty as to merchantability or any other warranty, expressed or implied. No representative of ours has any authority to waive or change the foregoing provisions unless in a specific agreement signed by the officers of seller and manufacturer. Ultimately, sellers and manufacturers only obligation shall be to replace or credit such quantity of the product proved to be defective at its discretion.

™ Trademark of Morgan Adhesives Company LLC
 ® Registered Trademark of Morgan Adhesives Company LLC
 www.Mactac.com

