

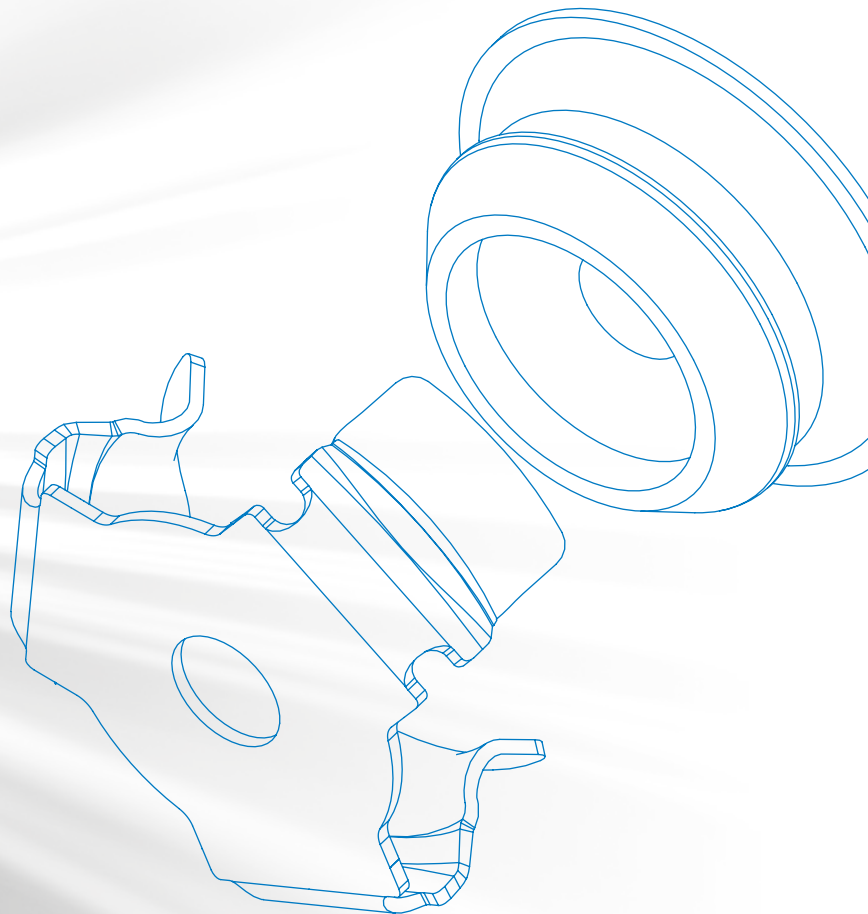

FAST-CON®

SISTEMA DI FISSAGGIO RAPIDO A PRESSIONE IN ACCIAIO INOX
STAINLESS STEEL QUICK SNAP-ON FASTENING SYSTEM



PRODOTTI ITALIANI DA SEMPRE | ITALIAN MANUFACTURES SINCE EVER



Specialinsert®
OUR TRADITION IS TO INNOVATE.

FAST-CON® è un sistema brevettato di fissaggio metallico a scatto che permette di collegare rapidamente pannellature e rivestimenti mediante una semplice pressione; l'eventuale rimozione avviene esercitando una lieve trazione del pannello. Il sistema a clip **FAST-CON®** permette di ottenere un fissaggio meccanico a scomparsa rendendo l'unione di 2 elementi rapida e affidabile.

FAST-CON® è realizzato da 2 elementi, maschio e femmina, in acciaio inossidabile, con profilo speciale adatto alla connessione rapida fra loro. L'installazione del **FAST-CON®** avviene mediante avvitatura, incollaggio o rivettatura. Le clip prevedono una forza di sgancio (7 kg e 10 kg) che varia a seconda della serie impiegata.

Il sistema brevettato **FAST-CON®** flottante permette di realizzare una regolazione della posizione di fissaggio del pannello rispetto alla struttura.

FAST-CON® is a patented metal snap-on fastening system that allows you to quickly connect panels and coverings by simply pressing; any removal occurs by exerting a slight traction on the panel. The **FAST-CON®** clip system allows for a concealed mechanical fixing, making the union of 2 parts quick and reliable.

FAST-CON® is made of 2 parts, male and female, in stainless steel, with a special profile suitable for quick connection between them. **FAST-CON®** is installed by screwing, bonding or riveting. The clips have a release force (7kg and 10kg) that varies depending on the series used.

The patented floating **FAST-CON®** system allows for adjustment of the panel's fixing position relative to the structure.

Applicazioni Applications

Pannellature, controsoffitti, boiserie, rivestimenti asportabili, sedute rimovibili, ante mobili arredo, personalizzazioni desktop pubblicitari, ecc.

Paneling, false ceilings, boiserie, removable coverings, removable seats, furniture doors, advertising desktop customizations, etc.

VANTAGGI/BENEFITS:

- Facile e rapida installazione | *Quick and easy installation*
- Flessibilità di impiego | *Flexibility of use*
- Minimo Ingombro | *Minimum overall dimensions*
- Utilizzabile in ogni settore | *Can be used in every industry*
- Resistente alle fiamme | *Flames resistant*
- Resistente alla corrosione | *Corrosion resistant*
- Lunga durata rispetto ai più comuni sistemi in plastica | *Long-lasting life compared to the most common plastic systems*
- Possibilità di regolazione della posizione del pannello (con accessorio dedicato)
Possibility of adjusting the panel position (with dedicated accessory)



Fissaggio a scatto - prodotto brevettato
Snap-on fastening system - patented



Femmina/Female

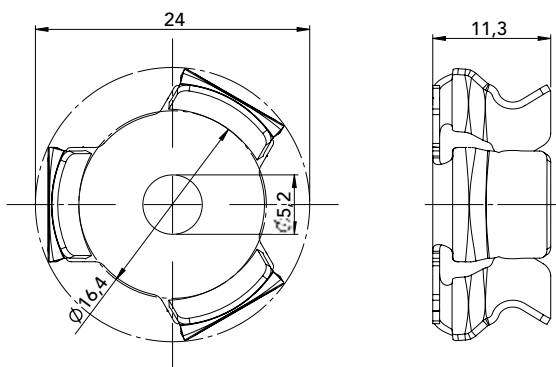

Codice Code	Materiale Material	Carico di Estrazione Extraction Load
FC-01-FE.51	Inox 316 Stainless steel 316	Min 7kg
FC-01-FE.53	Inox 301 Stainless steel 301	Min 10kg

Maschio/Male

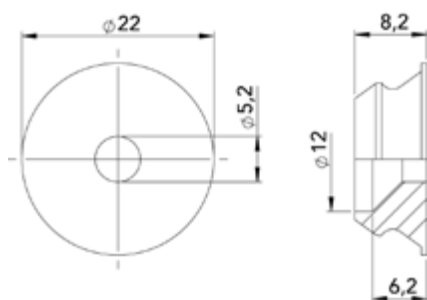

Codice Code	Materiale Material
FC-02-MA.51	Inox 316 Stainless steel 316
FC-02-MA.50	Inox 303 Stainless steel 303

FAST-CON® incassato
Built-in FAST-CON®

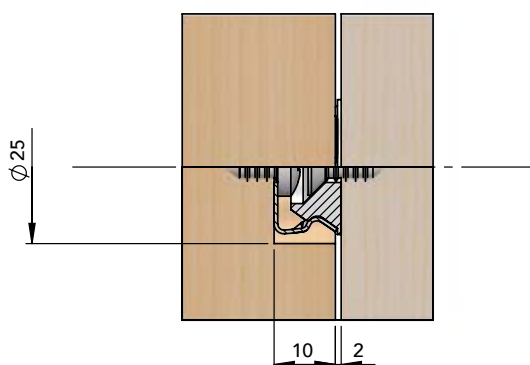

FAST-CON® a filo
FAST-CON® flush installation

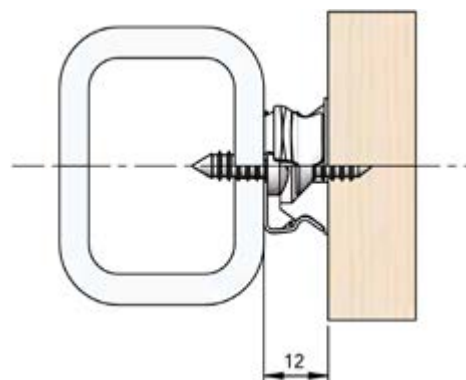

Le dimensioni, espresse in mm, ed i valori relativi al carico di estrazione sono indicativi e non vincolanti.
Dimensions, expressed in mm, and extraction load values are indicative and not binding.

GUIDA ALL'INSTALLAZIONE: FAST-CON® STANDARD

Standard FAST-CON® installation guide

Esempio di applicazione: pannello mobile a struttura

Application example: mobile panel with structure



Vista frontale | Front view



Vista laterale | Side view



1.

Fissare i **FAST-CON®** FC-01-FE.5_ femmina sulla struttura mediante avvitatura, incollaggio o rivettatura

Fasten the female **FAST-CON®** FC-01-FE.5_ on the structure by screwing, bonding or riveting



2.

Inserire i centrori FC-03-CE.01 nelle clip femmina

Insert the FC-03-CE.01 centering device into the female clips

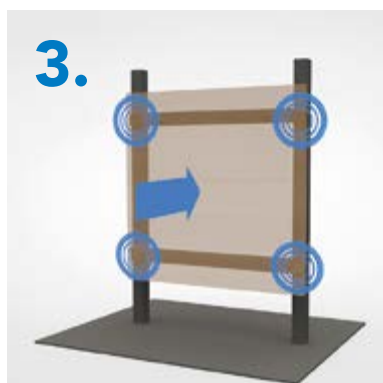

3.

Posizionare il pannello nel punto desiderato ed esercitare una leggera pressione. La marcatura fungerà da riferimento per il fissaggio dell'elemento maschio FC-02-MA.5_

Position the panel in the desired point and exert slight pressure. The marking will act as a reference for fastening the FC-02-MA.5_ male part

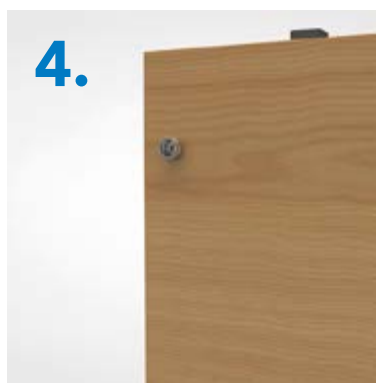

4.

Fissare l'elemento maschio FC-02-MA.5_ in corrispondenza delle marcature

Fasten the male part FC-02-MA.5_ at the markings



Guarda il video completo d'installazione/Get a look at the installation guide full video



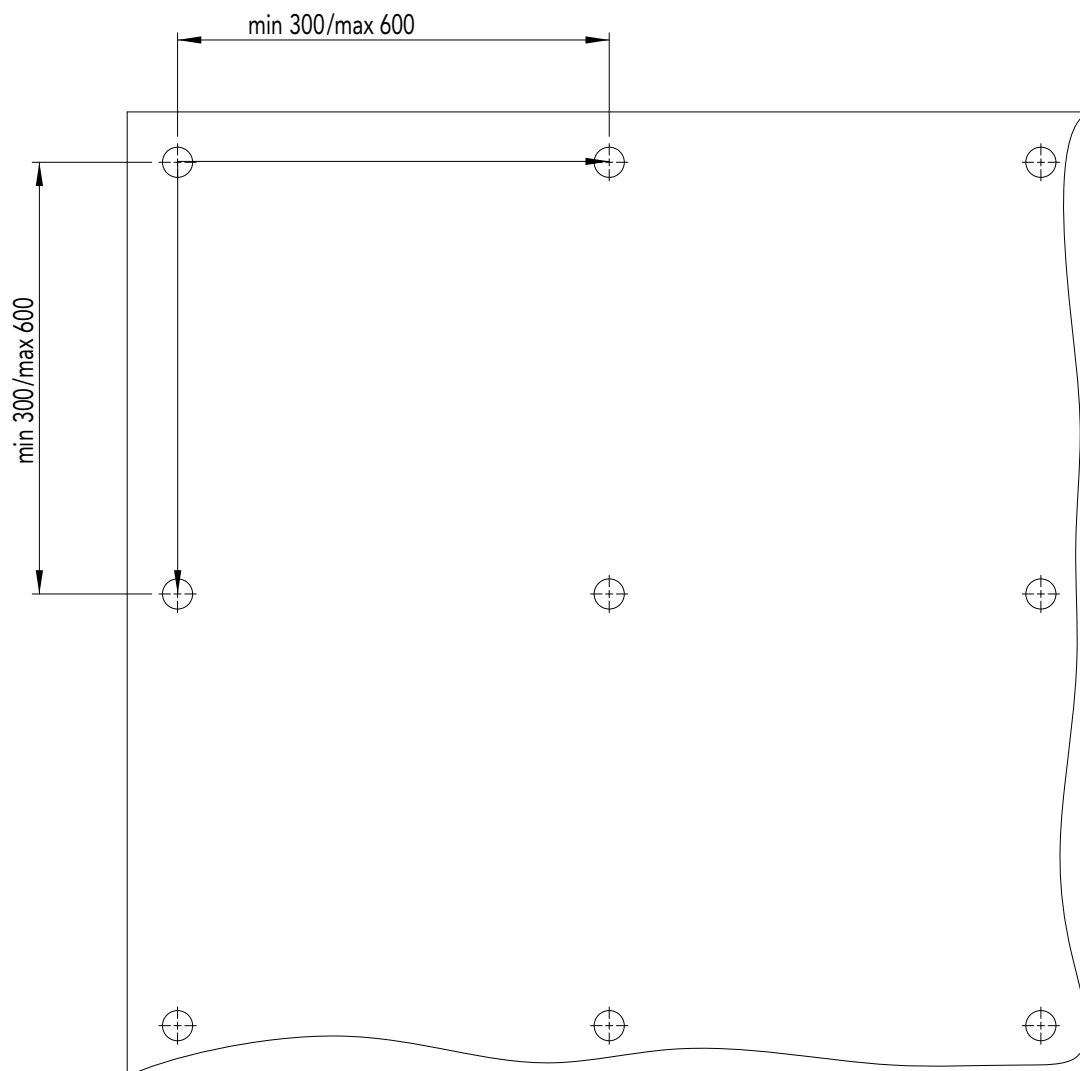

Le dimensioni sono indicative, non vincolanti, espresse in mm. Si consiglia sempre di effettuare delle prove.
Dimensions are indicative and not binding, expressed in mm. It is always recommended to carry out tests.

La distanza dal bordo e l'interasse possono variare a seconda della tipologia d'installazione, della natura del pannello e della struttura.

The distance from the edge and the center may vary depending on the type of installation, the nature of the panel and the fixed structure.



ACCESSORI

Accessories

FC-03-CE.01

Centratore in plastica
Plastic centering device



FC-00-LE.12

Leva di sgancio
Release lever



FC-01-AF.51

Anello flottante in acciaio inox 316L
Floating ring in stainless steel 316L



SISTEMI DI FISSAGGIO E INSTALLAZIONE

Fixing and installation systems

VTB4.8X9.5.51

Vite autofilettante 4,8x9,5 mm in acciaio inox
4,8x9,5mm stainless steel self-tapping screw



Collante

Adhesive



GUIDA ALL'INSTALLAZIONE: FAST-CON® FLOTTANTE

Floating FAST-CON® installation guide

Esempio di applicazione: pannello mobile a struttura

Application example: mobile panel with structure

1.

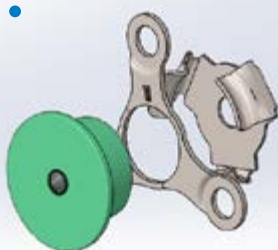

Preassemblare a scatto i particolari **FAST-CON®** femmina FC-01-FE.5_, anello flottante FC-01-AF.51, centratore FC-03-CE.01

Pre-assemble the **FAST-CON®** parts: female FC-01-FE.5_, floating ring FC-01-AF.51 and centering device FC-03-CE.01, by snapping them together

2.

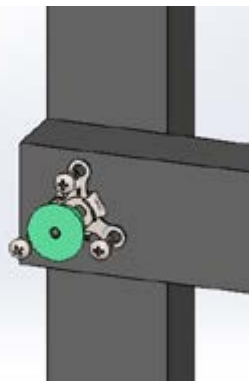

Fissare l'insieme **FAST-CON®** femmina sulla struttura mediante avvitatura, incollaggio o rivettatura

Fasten the female **FAST-CON®** assembly to the structure by screwing, bonding or riveting

3.

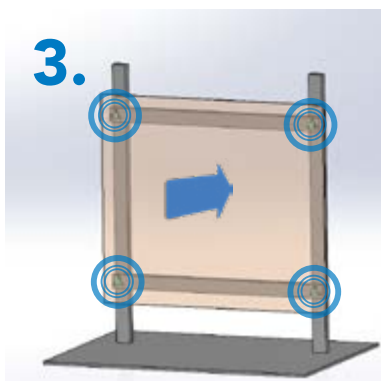

Posizionare il pannello nel punto desiderato ed esercitare una leggera pressione. La marcatura servirà da riferimento per il fissaggio dell'elemento maschio FC-02-MA.5_

Position the panel in the desired point and exert slight pressure. The marking will act as a reference for fastening the FC-02-MA.5_ male part

4.



Fissare l'elemento maschio FC-02-MA.5_ in corrispondenza delle marcature

Fasten the male part FC-02-MA.5_ at the markings

5.

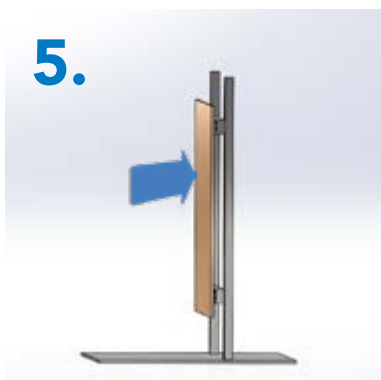

Rimuovere i centratori FC-03-CE.01 Fissare nuovamente il pannello alla struttura

Remove the FC-03-CE.01 centering devices. Re-attach the panel to the structure

6.

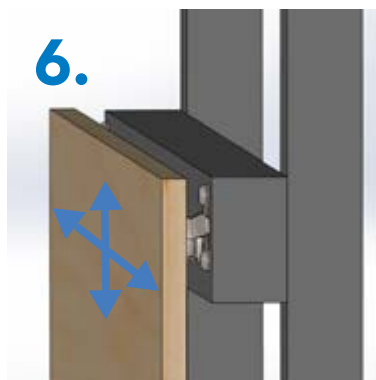

Ricercare la posizione voluta. Al termine, rimuovere il pannello con un movimento perpendicolare all'asse delle clip

Find the desired position. When finished, remove the panel with a movement perpendicular to the clip axis

7.



Fissare i **FAST-CON®** femmina FC-01-FE.5_ sulla struttura mediante avvitatura

Fasten the female **FAST-CON®** FC-01-FE.5_ on the structure by screwing



Specialinsert® è un'azienda presente nel mondo dei sistemi di fissaggio dal 1974. Nasce per iniziativa di tre tecnici commerciali che, grazie alla loro esperienza nel settore dei fastener, decidono di avviarne la commercializzazione in proprio, affiancandole negli anni l'attività di fabbricazione.

Specialinsert® was established in 1974 by three sales agents who decided to exploit their experience in the fasteners industry to start up their own retail business. The company later developed and started its own production.

Con tre unità locali, due depositi, due siti di produzione italiani, un ufficio R&S e due laboratori prove, **Specialinsert®** è in grado di fornire ai clienti soluzioni sempre più avanzate e adatte ai diversi problemi di fissaggio.

With three local branches, two warehouses, two production plants in Italy, an R&D office and two testing labs, **Specialinsert®** supplies cutting edge solutions suited to solving the most diverse fastening problems.

Specialinsert® vanta una serie di proposte con soluzioni di fissaggio meccanico adatte a vari settori di applicazione: laminati tubolari metallici, componenti meccanici e plastici, legno, lapidei, nuovi materiali compositi e materiali innovativi quali solid surface; questi ultimi indicati particolarmente per applicazioni su arredi o edifici.

Specialinsert® offers a series of proposals with mechanical fixing solutions suitable for various application sectors such as: metal tubular laminates, mechanical and plastic components, wood, stone, new composite materials and innovative materials such as solid surface; the latter particularly suitable for applications on furniture or buildings.

PRODOTTI - PRODUCTS

LAMINATI METAL SHEETS

Inserti per laminati, profilati, tubolari
Inserts for sheet metal, section bars, tubes



CORPI SOLIDI SOLID PARTS

Inserti per corpi solidi, legno, metallo
Inserts for solid, wood, metal parts



PLASTICA PLASTIC

Inserti per materie plastiche
Inserts for plastic materials



COMPOSITI COMPOSITES

Inserti per materiali compositi
Inserts for composite materials



Nel costante impegno di migliorare i propri prodotti **Specialinsert®** si riserva il diritto di modificare le caratteristiche tecniche e costruttive senza preavviso: si invita a verificare eventuali aggiornamenti sulle schede tecniche pubblicate sul nostro sito www.specialinsert.it. Proprietà e diritti del documento sono riservati. Ne è vietata la riproduzione, anche parziale e la diffusione a terzi senza autorizzazione.

Specialinsert® is dedicated to the continuous improvement of its products and for this reason reserves the right to make any modifications to its technical or engineering specifications without notice: for the latest updates please refer to the technical data sheets published on our website www.specialinsert.it. This document is protected by copyright. None of its parts may be reproduced or transmitted to third parties without permission.

Specialinsert® è associata UNI, Ente Nazionale di Unificazione. Membro della Commissione Organi Meccanici.
Specialinsert® is UNI associated, National Unification Body. Member of the Mechanical Orders Commission.

Specialinsert® al fianco delle università per innovare. **Specialinsert®** alongside universities on innovations.



WWW.SPECIALINSERT.IT

INFO@SPECIALINSERT.IT - EXPORT@SPECIALINSERT.IT

SEDE TORINO | HEADQUARTERS AND EXPORT DEPARTMENT

Via Monfalcone, 144 - 10136 - Torino (Italy) - Tel. +39 011.700.301 R.A.

FILIALI E STABILIMENTO | PRODUCTION DEPARTMENT AND BRANCH

Via E. Cialdini 37 - 20161 - Milano (Italy) - Tel. +39 02.646.84.76 R.A.

Via E. Pavanello 1 - 30030 - Maerne di Martellago (VE - Italy) - Tel. +39 041.503.01.00 R.A.

