

Application: resins, composites materials, other materials.
Assembly: by riveting.

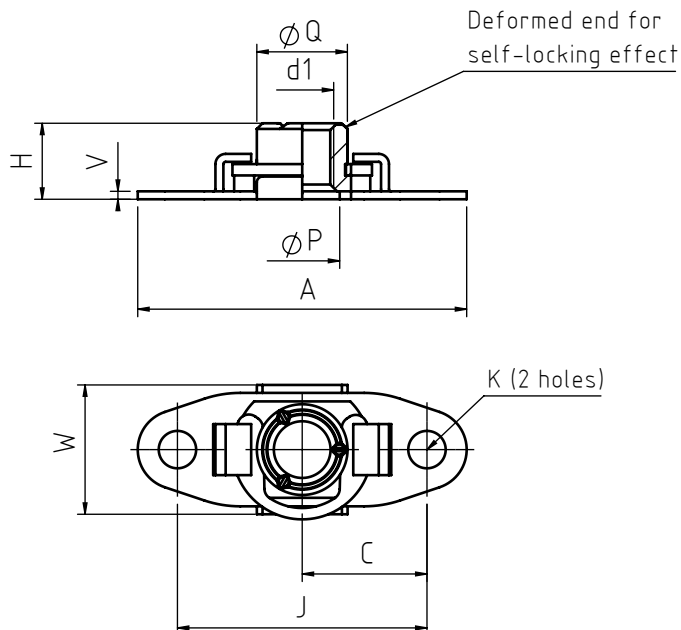

CODE	d1 thread 6H	A max	C +0,05/ -0,05	H max	J +0,1/ -0,1	P min.	Q +0,05/ -0,05	V max	W max	K
OAFRS 0040.62	M4x0,7	29	11	6,7	22	8	8	0,7	11,4	3,3
OAFRS 0050.62	M5x0,8									
OAFRS 0060.62	M6x1									

Non binding dimensions, expressed in mm.

 Standard

 On demand

Plate material: stainless steel n° 1.4404 (AISI 316 L)
Plate finishing: natural state
Bush material: steel n° 1.0736 (AVZ)
Bush finishing: Fe/Zn Ni 7 IV S
Retaining ring material: carbon steel
Retaining ring finishing: burnished

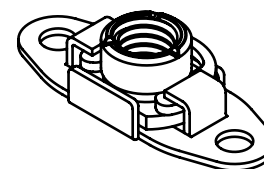

Tolerance d1: respected in the non-deformed useful section.
Use not intended with stainless steel screws.

Bush replacement

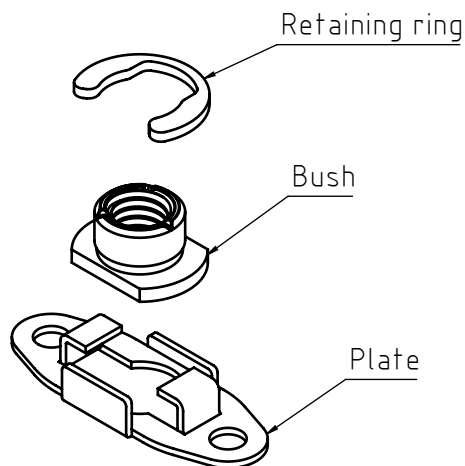

The self-locking bush guarantees a solid, vibration-resistant fastening.
The self-locking effect gradually diminishes after repeated screwing/unscrewing cycles.
FLOAT-NUT makes it easy to replace the bush with a new one without affecting the plate.

Bush replacement:

Remove the retaining ring to free the bush.

After the bush has been replaced, put the ring back in its seat.

It is recommended to replace the retaining ring each time the bush is replaced.

SPARE PARTS KIT		
CODE	BUSH THREAD	DESCRIPTION
OAFRS KIT 0040	M4	ZINC PLATED SELF-LOCKING BUSH + RETAINING RING M4 - 30 PIECES KIT
OAFRS KIT 0050	M5	ZINC PLATED SELF-LOCKING BUSH + RETAINING RING M5 - 30 PIECES KIT
OAFRS KIT 0060	M6	ZINC PLATED SELF-LOCKING BUSH + RETAINING RING M6 - 30 PIECES KIT

Spare parts are not sold individually.

NEL COSTANTE IMPEGNO DI MIGLIORARE I PROPRI PRODOTTI LA SPECIALINSERT® SI RISERVA IL DIRITTO DI MODIFICARE LE CARATTERISTICHE TECNICHE E COSTRUTTIVE SENZA PREAVVISO. PROPRIETÀ E DIRITTI DEL DOCUMENTO SONO RISERVATI. NE È VIETATA LA RIPRODUZIONE, ANCHE PARZIALE E LA DIFFUSIONE A TERZI SENZA AUTORIZZAZIONE.